

9100 Series Base Mounted Centrifugal Fire Pumps

Installation, Operation, and Service Instructions

INSTALLER: PLEASE LEAVE THIS MANUAL FOR THE OWNER'S USE.

Engineered for life

TABLE OF CONTENTS

<p>DESCRIPTION.....3</p> <p>OPERATIONAL LIMITS3</p> <p>MAXIMUM WORKING PRESSURE3</p> <p>SEAL OPERATING LIMITS3 PACKING3</p> <p>PUMP IDENTIFICATION3</p> <p>SAFETY INSTRUCTIONS4</p> <p>ADDITIONAL SAFETY REQUIREMENTS5 ELECTRICAL SAFETY5 THERMAL SAFETY5 MECHANICAL SAFETY5</p> <p>PUMP LOCATION6</p> <p>INTRODUCTION.....7 1. PURPOSE OF MANUAL7 2. WARRANTY7 3. PUMP IDENTIFICATION7 4. INSTALLATION7 5. RECEIVING PUMP7 6. TEMPORARY STORAGE7 7. LOCATION7 8. FOUNDATION.....8 9. BASE PLATE SETTING (BEFORE PIPING)8 10. GROUTING PROCEDURE9 11. SEE ANSI/OSHA COUPLER GUARD REMOVAL/INSTALLATION9 12. ALIGNMENT PROCEDURE9 13. ANSI/OSHA COUPLER GUARD REMOVAL/INSTALLATION9 14. DOWELING15 15. SUCTION AND DISCHARGE PIPING..15 16. STUFFING BOX LUBRICATION.....18 17. PACKING18</p> <p>OPERATION20 1. PRE-START CHECKS20 2. PRIMING20 3. STARTING20 4. OPERATING CHECKS20 5. FREEZING PROTECTION.....21</p> <p>CHANGING ROTATION22</p> <p>MAINTENANCE.....25</p>	<p> 1. GENERAL MAINTENANCE..... 25</p> <p> 2. MAINTENANCE OF PUMP DUE TO FLOOD DAMAGE 25</p> <p> 3. BEARING LUBRICATION – GREASE ... 25</p> <p> 4. PACKING SEAL..... 26</p> <p> 5. CLEANING WITHOUT DISMANTLING PUMP 26</p> <p>MAINTENANCE TIME TABLE..... 27</p> <p>SERVICE INSTRUCTIONS 28 DISASSEMBLY AND REASSEMBLY PROCEDURES 28 DISMANTLING (PUMP WITH PACKING) ..28 ASSEMBLY (PUMP WITH PACKING) 30</p> <p>APPENDIX “A” 33 EXPLODED VIEW 33 REPLACEMENT PARTS LIST 34 LIMITED END FLOAT COUPLINGS 35 ORDERING PARTS..... 35</p> <p>DEALER SERVICING 36</p> <p style="text-align: center;">NOTE</p> <p>The information contained in this book is intended to assist operating personnel by providing information on the characteristics of the purchased equipment.</p> <p>It does not relieve the user of their responsibility of using accepted engineering practices in the installation, operation, and maintenance of this equipment.</p> <p>Any further questions, contact ITT A-C Pump, (847) 966-3700.</p>
--	--

DESCRIPTION

The 9100 Series Centrifugal Fire Pumps are frame mounted pumps which feature – high efficiency, rugged construction, compact design, foot mounted volute and regreasable bearings. These features, along with the horizontal split case, make installation, operation and service easy to perform.

OPERATIONAL LIMITS

Unless special provisions have been made for your pump by ITT A-C Fire Pump Systems, the operational limits for 9100 Series Centrifugal Fire Pumps are as follows:

MAXIMUM WORKING PRESSURE

Listed on pump nameplate.

SEAL OPERATING LIMITS

PACKING

PH Limitations 7-9; Temperature Range 0 to +200°F

For use on open or closed systems which require a large amount of makeup water, as well as systems which are subjected to widely varying chemical conditions and solids buildup.

PUMP IDENTIFICATION

Permanent records for this pump are referenced by the Serial Number and it must, therefore, be used with all correspondence to order all spare and replacement parts. The fourth digit indicates the specific pump on orders for more than one pump. For example, if an order called for six pumps, all pumps would have the same first three sets of digits and the last digit will change to identify each of the six. (e.g. 03-123456-01-01, 03-123456-01-02, etc.)

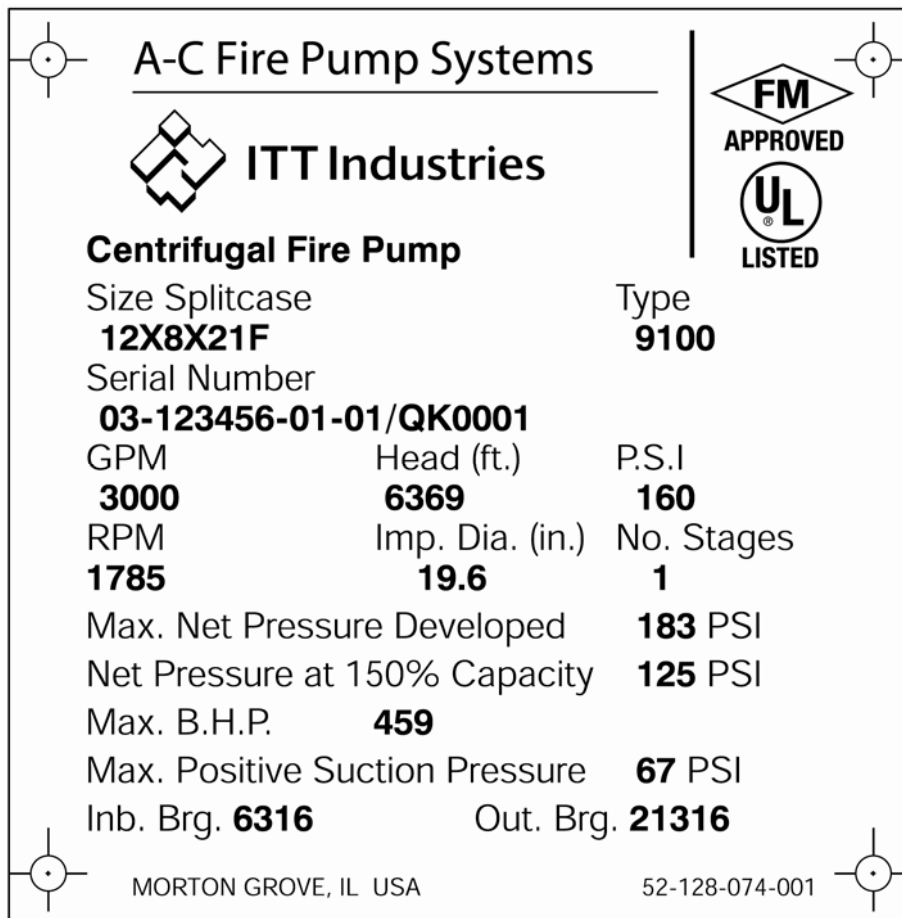

FIGURE 1 – RATING PLATE

SAFETY INSTRUCTIONS

SAFETY INSTRUCTIONS

This safety alert symbol will be used in this manual and on the pump safety instruction decals to draw attention to safety related instructions. When used the safety alert symbol means ATTENTION! BECOME ALERT! YOUR SAFETY IS INVOLVED! FAILURE TO FOLLOW THE INSTRUCTIONS MAY RESULT IN A SAFETY HAZARD.

Your 9100 Series Centrifugal Fire Pump should have the following safety instruction decals displayed. If the decals are missing or illegible contact your local ITT AC Fire Pump Systems representative for a replacement.

Additional Safety Requirements:

1. Electrical connections to be made by qualified Electrician in accordance with all national, state and local codes.
2. Motor must have properly sized starter with properly sized heaters to provide overload and undervoltage protection.
3. If pump, motor or piping are operating at extremely high or low temperatures, guarding or insulation is required.
4. The maximum working pressure of the pump is listed on the pump nameplate, do not exceed this pressure.

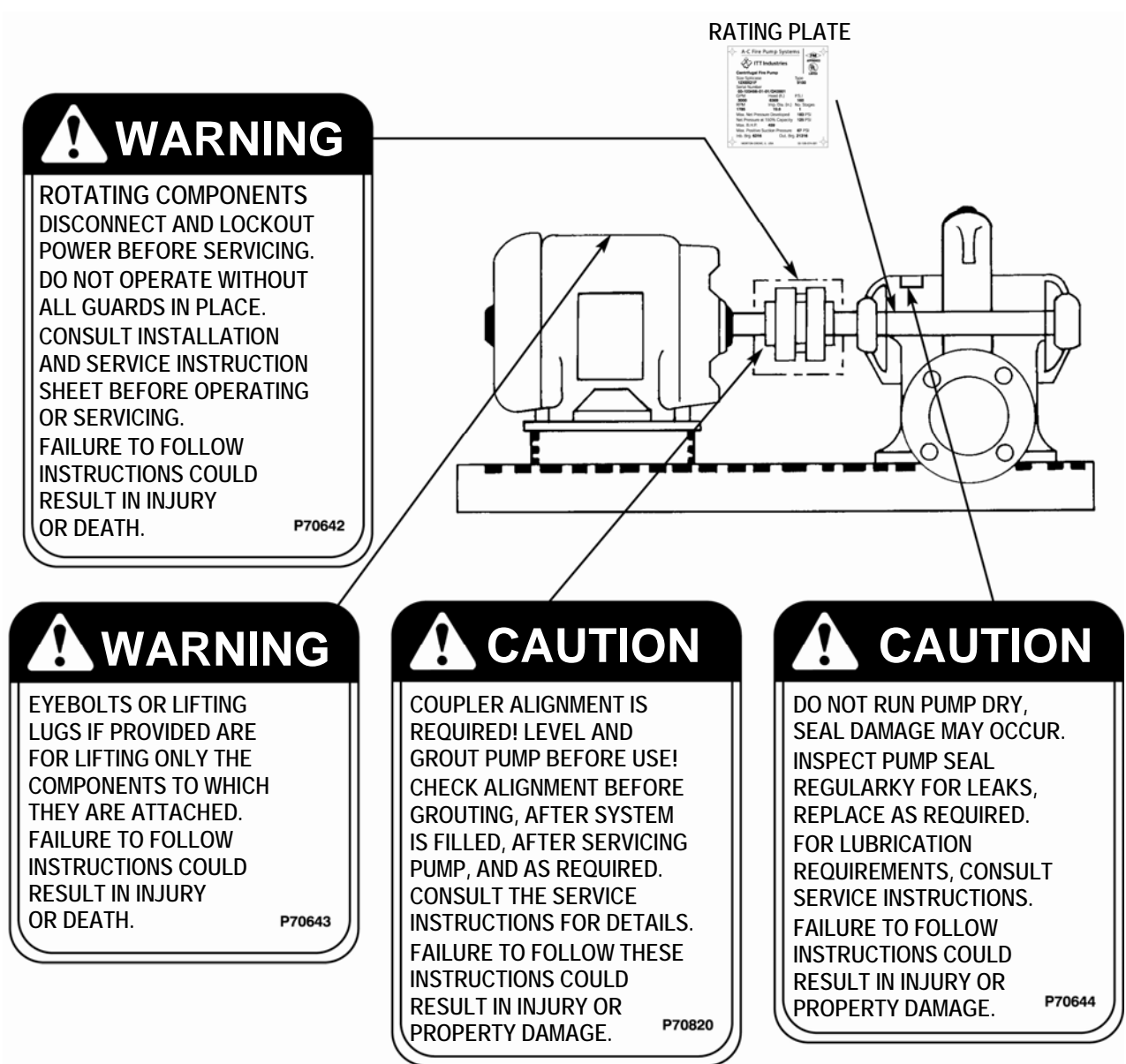

FIGURE 2 – SAFETY INSTRUCTION DECALS

ADDITIONAL SAFETY REQUIREMENTS

ELECTRICAL SAFETY



WARNING: Electrical Shock Hazard

Electrical connections to be made by a qualified electrician in accordance with all applicable codes, ordinances, and good practices. Failure to follow these instructions could result in serious personal injury or death, and property damage.



WARNING: Electrical Overload Hazard

Three phase motors must have properly sized heaters to provide overload and under voltage protection. Single-phase motors have built-in overload protectors. Failure to follow these instructions could result in serious personal injury or death, and property damage.

THERMAL SAFETY



WARNING: Extreme Temperature Hazard

If pump, motor, or piping is operating at extremely high or low temperature, guarding or insulation is required. Failure to follow these instructions could result in serious personal injury or death, and property damage.

MECHANICAL SAFETY



WARNING: Unexpected Startup Hazard

Disconnect and lockout power before servicing. Failure to follow these instructions could result in serious personal injury or death, and property damage.



WARNING: Excessive System Pressure Hazard

The maximum working pressure of the pump is listed on the nameplate, do not exceed this pressure. Failure to follow these instructions could result in serious personal injury or death, and property damage.



WARNING: Excessive Pressure Hazard Volumetric Expansion

The heating of water and other fluids causes volumetric expansion. The associated forces may cause failure of system components and release of high temperature fluids. Installing properly sized and located compression tanks and pressure relief valves will prevent this. Failure to follow these instructions could result in serious personal injury or death, and property damage.

PUMP LOCATION

Locate the pump so there is sufficient room for inspection, main-tenance and service. If the use of a hoist or tackle is needed, allow ample head room.



WARNING: Falling Objects Hazard

Eyebolts or lifting lugs, if provided, are for lifting only the components to which they are attached. Failure to follow these instructions could result in serious personal injury or death, or property damage.

If lifting base pump is required, use a nylon string, chain, or wire rope, hitch around both bearing supports. If lifting of the entire pump is required, do so with slings placed under the base rails as shown.

Care must be taken to size equipment for unbalanced loads which may exist if the motor is not mounted on the base at the time of lifting. Motor may or may not be mounted at the factory.

Pump, base, and driver assemblies where the base length exceeds 100 inches may not be safe to lift as a complete assembly. Damage to the baseplate may occur. If the driver has been mounted on the baseplate at the factory, it is safe to lift the entire assembly. If the driver has not been mounted at the factory, and the overall baseplate length exceeds 100 inches, do not lift the entire assembly consisting of pump, base, and driver. Instead, lift the pump and baseplate to its final location without the driver. Then mount the driver.

The best pump location for sound and vibration absorption is on a concrete floor with subsoil underneath. If the pump location is overhead, special precautions should be undertaken to reduce possible sound transmission. Consult a sound specialist.

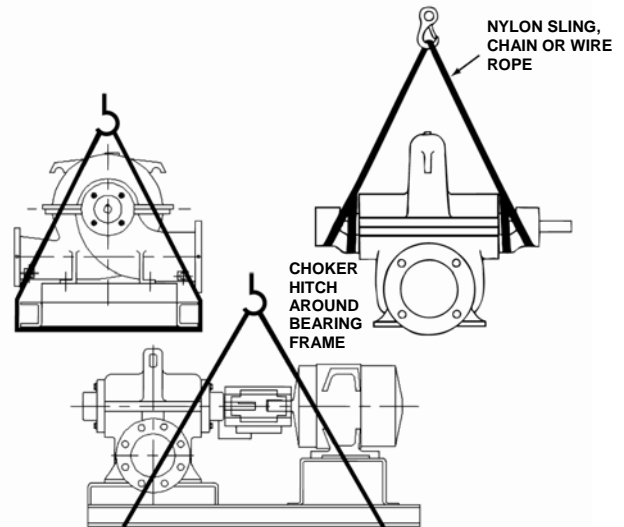

FIGURE 3

If the pump is not on a closed system, it should be placed as near as possible to the source of the liquid supply, and located to permit installation with the fewest number of bends or elbows in the suction pipe.

The installation must be evaluated to determine that the Net Positive Suction Head Available (NPSHA) meets or exceeds the Net Positive Suction Head Required (NPSHR), as stated by the pump performance curve. See page 15 for more details on proper suction piping installation.

INTRODUCTION

1. PURPOSE OF MANUAL

This manual is furnished to acquaint you with some of the practical ways to install, operate, and maintain this pump. Read it completely before doing any work on your unit and keep it handy for future reference.

Equipment cannot operate well without proper care. To keep this unit at top efficiency, follow the recommended installation and servicing procedures outlined in this manual.

2. WARRANTY

Refer to your local representative for warranty coverage.

3. PUMP IDENTIFICATION

All pumps are designated by Serial Number, Model Number, and Size. This information is stamped on an identification plate which is mounted on the pump.

4. INSTALLATION

5. RECEIVING PUMP

Check pump for shortages and damage immediately upon arrival. (An absolute must.) Prompt reporting to the carrier's agent with notations made on the freight bill, will expedite satisfactory adjustment by the carrier.

Pumps and drivers normally are shipped from the factory mounted and painted with primer and one finish coat. Couplings may be either completely assembled or have the coupling hubs mounted on the shafts and the connecting members removed. When the connecting members are removed, they will be packaged in a separate container and shipped with the pump or attached to the base plate.

Shafts are in alignment when the unit is shipped; however, due to shipping, the pumps may arrive misaligned and, therefore, alignment must be established during installation. ITT AC Fire Pump Systems has determined that proper and correct alignment can only be made by accepted erection practices. Refer to the following paragraphs on "Foundation," "Base Plate Setting," "Grouting Procedure," "Alignment Procedure" and "Doweling."

6. TEMPORARY STORAGE

If the pump is not to be installed and operated soon after arrival, store it in a clean, dry place having slow, moderate changes in ambient temperature. Rotate the shaft periodically to coat the bearings with lubricant and to retard oxidation, corrosion, and to reduce the possibility of false brinelling of the bearings.

7. LOCATION

The pump should be installed as near the suction supply as possible, but no less than five suction diameters (refer to page 15, suction and discharge piping section) with the shortest and most direct suction pipe practical. The total dynamic suction lift (static lift plus friction losses in suction line) should not exceed the limits for which the pump was sold.

The pump must be primed before starting. Whenever possible, the pump should be located below the fluid level to facilitate priming and assure a steady flow of liquid. This condition provides a positive suction head on the pump. It is also possible to prime the pump by pressurizing the suction vessel.

When installing the pump, consider its location in relation to the system to assure that sufficient Net Positive Suction Head (NPSH) at pump suction is provided. Available NPSH must always equal or exceed the required NPSH of the pump.

The pump should be installed with sufficient accessibility for inspection and maintenance. A clear space with ample head room should be allowed for the use of an overhead crane or hoist sufficiently strong to lift the unit.

NOTE: Allow sufficient space to be able to dismantle pump without disturbing the pump inlet and discharge piping.

Select a dry place above the floor level wherever possible. Take care to prevent pump from freezing during cold weather when not in operation. Should the possibility of freezing exist during a shut-down period, the pump should be completely drained, and all passages and pockets where liquid might collect should be blown out with compressed air.

Make sure there is a suitable power source available for the pump driver. If motor driven, electrical characteristics should be identical to those shown on motor data plate.

8. FOUNDATION

A substantial foundation and footing should be built to suit local conditions. The foundation must be substantial enough to absorb vibration. (Hydraulic Institute Standards recommends the foundation weigh at least five (5) times the weight of the pump unit.) It must form a permanent and rigid support for the baseplate. This is important in maintaining the alignment of the flexibly coupled unit.

The foundation should be poured without interruption to within 1/2 to 1-1/2 inches of the finished height. The top surface of the foundation should be well scored and grooved before the concrete sets; this provides a bonding surface for the grout.

Foundation bolts should be set in concrete as shown in Figure 4. An optional 4-inch long tube around the bolts at the top of the concrete will allow some flexibility in bolt alignment to match the holes in the base plate. Allow enough bolt length for grout, shims, lower base plate flange, nuts and washers. The foundation should be allowed to cure for several days before the base plate is shimmed and grouted.

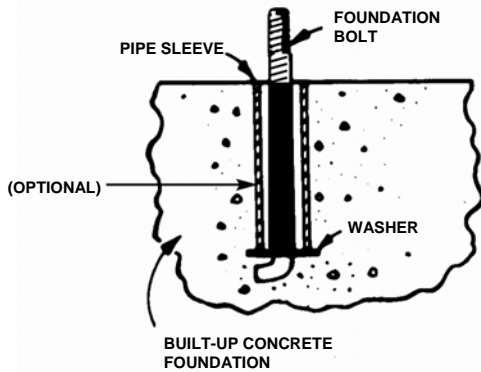

FIGURE 4 – FOUNDATION

9. BASE PLATE SETTING (BEFORE PIPING)

NOTE: This procedure assumes that a concrete foundation has been prepared with anchor or hold down bolts extending up ready to receive unit. It must be understood that pump and motor have been mounted and rough aligned at the factory. If motor is to be field mounted, consult factory for recommendations. ITT AC Fire Pump Systems cannot assume responsibility for final alignment.

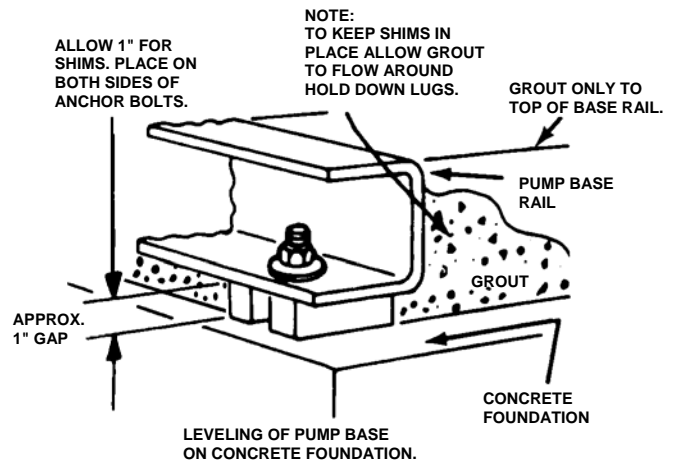

FIGURE 5 – SETTING BASE PLATE AND GROUTING

- Use blocks and shims under base for support at anchor bolts and midway between bolts, to position base approximately 1" above the concrete foundation, with studs extending through holes in the base plate.
- By adding or removing shims under the base, level and plumb the pump shaft and flanges. The base plate does not have to be level.
- Draw anchor nuts tight against base, and observe pump and motor shafts or coupling hubs for alignment. (Temporarily remove coupling guard for checking alignment.)
- If alignment needs improvement, add shims or wedges at appropriate positions under base, so that retightening of anchor nuts will shift shafts into closer alignment. Repeat this procedure until a reasonable alignment is reached.

NOTE: Reasonable alignment is defined as that which is mutually agreed upon by pump contractor and the accepting facility (final operator). Final alignment procedures are covered under "Alignment Procedures."

- Check to make sure the piping can be aligned to the pump flanges without placing pipe strain on either flange.
- Grout in base plate completely (See "Grouting Procedure") and allow grout to dry thoroughly before attaching piping to pump. (24 hours is sufficient time with approved grouting procedure.)

10. GROUTING PROCEDURE

Grout compensates for uneven foundation, distributes weight of unit, and prevents shifting. Use an approved, non-shrinking grout, after setting and leveling unit (See Figure 5).

- a. Build strong form around the foundation to contain grout.
- b. Soak top of concrete foundation thoroughly, then remove surface water.
- c. Base plate should be completely filled with grout.
- d. After the grout has thoroughly hardened, check the foundation bolts and tighten if necessary.
- e. Check the alignment after the foundation bolts are tightened.
- f. Approximately 14 days after the grout has been poured or when the grout has thoroughly dried, apply an oil base paint to the exposed edges of the grout to prevent air and moisture from coming in contact with the grout.

11. SEE ANSI/OSHA COUPLER GUARD REMOVAL/INSTALLATION

(page 9)

12. ALIGNMENT PROCEDURE

NOTE: A flexible coupling will only compensate for small amounts of misalignment. Permissible misalignment will vary with the make of coupling. Consult coupling manufacturer's data when in doubt.

Allowances are to be made for thermal expansion during cold alignment, so that the coupling will be aligned at operating temperature. In all cases, a coupling must be in alignment for continuous operation. Even though the coupling may be lubricated, misalignment causes excessive wear, vibration, and bearing loads that result in premature bearing failure and ultimate seizing of the pump. Misalignment can be angular, parallel, or a combination of these, and in the horizontal and vertical planes. Final alignment should be made by moving and shimming the motor on the base plate, until the coupling hubs are within the recommended tolerances measured in total run-out. All measurements should be taken with the pump and motor foot bolts tightened. The shaft of sleeve bearing

motors should be in the center of its mechanical float.

NOTE: Proper alignment is essential for correct pump operation. This should be performed after base plate has been properly set and grout has dried thoroughly according to instructions. Final alignment should be made by shimming driver only. Alignment should be made at operating temperatures.



WARNING: Unexpected Start-up Hazard

Disconnect and lock out power before servicing. Failure to follow these instructions could result in serious personal injury or death and property damage.

13. ANSI/OSHA COUPLER GUARD REMOVAL/INSTALLATION



WARNING: Unexpected Start-up Hazard

Disconnect and lock out power before servicing. Failure to follow these instructions could result in serious personal injury or death and property damage.

NOTE: Do not spread the inner and outer guards more than necessary for guard removal or installation. Over spreading the guards may alter their fit and appearance.

Removal

- a. Remove the two capscrews that hold the outer (motor side) coupler guard to the support bracket(s).
- b. Spread the outer guard and pull it off the inner guard.
- c. Remove the capscrew that holds the inner guard to the support bracket.
- d. Spread the inner guard and pull it over the coupler.

Installation

- a. Check coupler alignment before proceeding. Correct if necessary.
- b. Spread the inner guard and place it over the coupler.
- c. With the inner guard straddling the support bracket, install a capscrew through the hole (or slot) in the support bracket and guard located closest to the pump. Do not tighten the capscrew.
- d. Spread the outer guard and place it over the inner guard.

e. Install the outer guard capscrews by following the step stated below which pertains to your particular pump:

- i. *For pumps with a motor saddle support bracket:* Ensure the outer guard is straddling the support arm, and install but do not tighten the two remaining capscrews.
- ii. *For pumps without a motor saddle support bracket:* Insert the spacer washer between the holes located closest to the motor in the outer guard,

and install, but do not tighten, the two remaining capscrews.

- f. Position the outer guard so it is centered around the shaft, and so there is less than a 1/4" of the motor shaft exposed. On guards that utilize a slotted support bracket, the inner guard will have to be positioned so there is only a 1/4" of the pump shaft exposed.
- g. Holding the guard in this position, tighten the three capscrews.

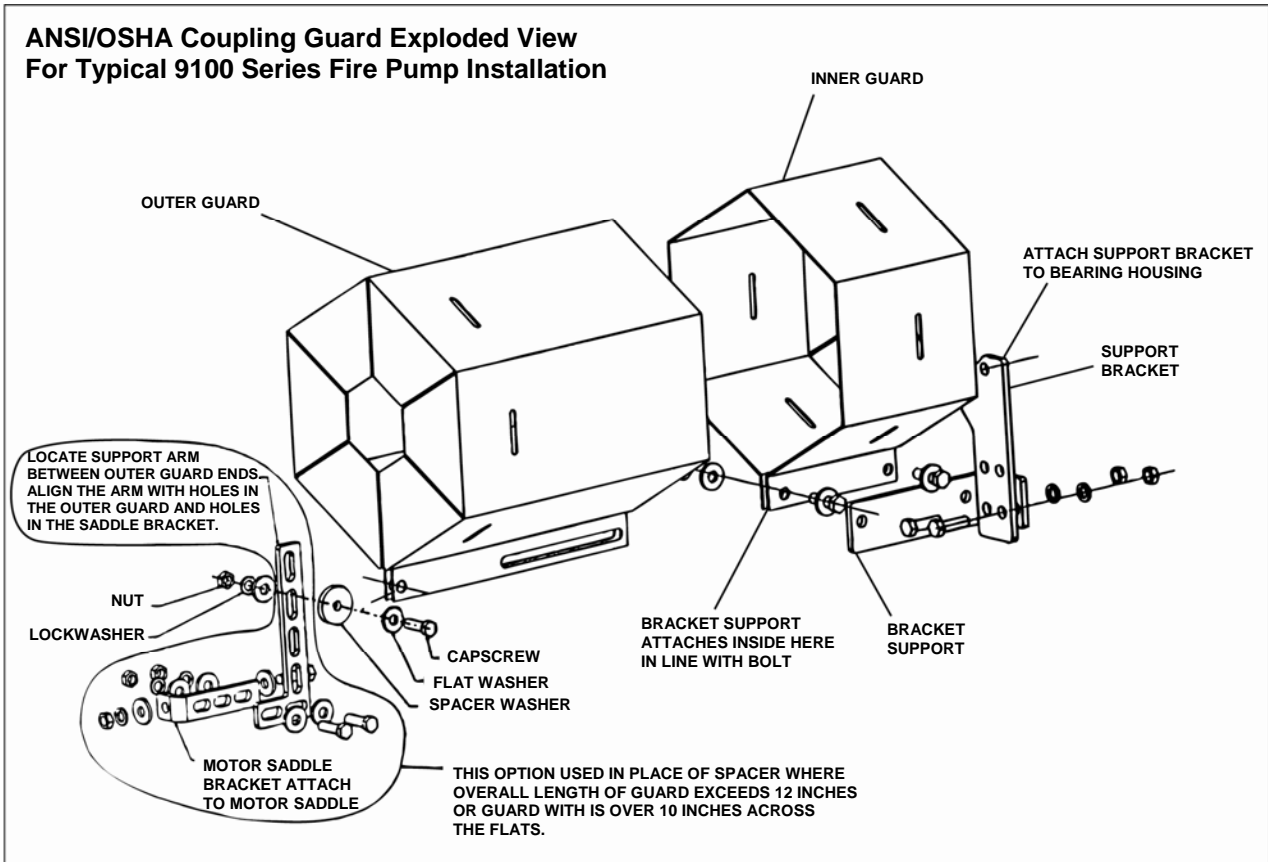

Method 1 – Straight Edge Alignment for Standard Sleeve Type Coupler with Black Rubber Insert

(See Figure 6A)

Proceed with this method only if satisfied that face and outside diameters of the coupling halves are square and concentric with the coupling borers. If this condition does not exist or elastomeric couplings do not make this method convenient, use Method 2.

1. Check angular misalignment using a micrometer or caliper. Measure from the outside of one flange to the outside of the opposite flange at four points 90° apart. **DO NOT ROTATE COUPLER.** Misalignment up to 1/64" per inch of coupler radius is permissible.
2. At four points 90° apart (**DO NOT ROTATE COUPLER**), measure the parallel coupler misalignment by laying a straight edge across one coupler half and measuring the gap between the straight edge and opposite coupler half. Up to a 1/64" gap is permissible.

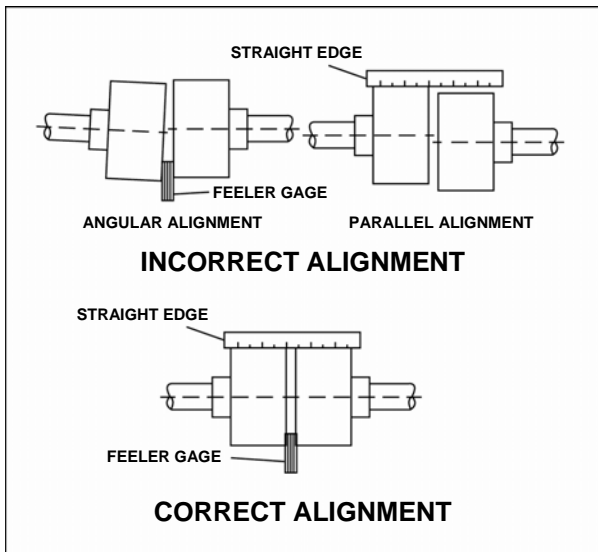

FIGURE 6A – CHECKING ALIGNMENT (Method 1)

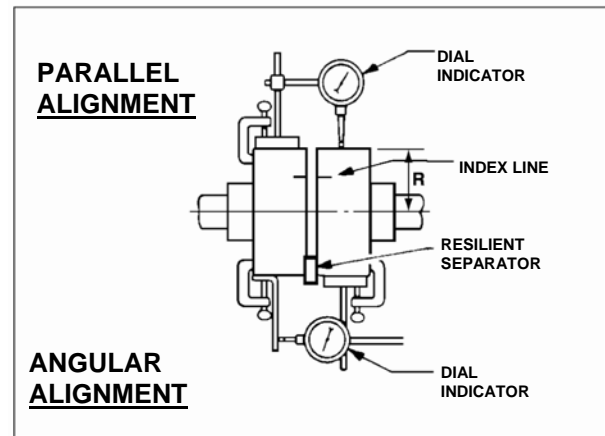

FIGURE 6B - CHECKING ALIGNMENT (Method 2)

Method 2 – For Orange Hytrel Insert, 3500 RPM Operation, or All Other Coupler Types Except as Noted Below

(See Figure 6B)

- a. Make sure each hub is secured to its respective shaft and that all connecting and/or spacing elements are removed at this time.
- b. The gap between the coupling hubs is set by the manufacturer before the units are shipped. However, this dimension should be checked. (Refer to the coupling manufacturer's specifications supplied with the unit.)
- c. Scribe index lines on coupling halves as shown in Figure 6B.
- d. Mount dial indicator on one hub as shown for parallel alignment. Set dial to zero.
- e. Turn both coupling halves so that index lines remain matched. Observe dial reading to see whether driver needs adjustment (See paragraph i below).
- f. Mount dial indicator on one hub as shown for angular alignment. Set dial to zero.
- g. Turn both coupling halves so that index lines remain matched. Observe dial reading to see whether driver needs adjustment (See paragraph i below).
- h. Assemble coupling. Tighten all bolts and set screw(s). It may be necessary to repeat steps c through f for a final check.
- i. For single element couplings, a satisfactory parallel misalignment is .004" T.I.R., while a satisfactory angular

misalignment is .004"T.I.R. per inch of radius R (See Figure 6B).

Grid Couplings

NOTE: The following procedure is intended for mounting and alignment of Rexnord Industries, LLC. and Clarke Fire Protection Products, Inc., Tapered Grid Couplings.

Adequate lubrication is essential for satisfactory operation. Grease supplied by the coupling manufacturer is highly recommended. Other greases to be used should be approved by the coupling manufacturer.

Alignment is shown using a spacer bar and straight edge. Rexnord Industries, LLC. and Clarke Fire Protection Products, Inc. state this practice has been proven for many industrial applications. Superior alignment can be achieved through the use of dial indicators as shown above.

1. Clean all metal parts using non-flammable solvent.
2. Lightly coat seals with coupling vendor supplied grease and place on shafts before mounting shaft hubs.
3. Install keys and mount hubs with flange faces flush with shaft ends or as otherwise specified.
4. Reposition hubs on shafts as required to achieve the required hub gap shown in Figure 6H or otherwise specified. The length of engagement on each shaft should be roughly equal to the shaft diameter.
5. Tighten setscrews.
6. Bring the pump and motor halves of the coupler into approximate height alignment, by placing equal amounts of shims under all the motor feet.
7. Tighten the motor bolts.
8. Use a spacer bar equal in thickness to the gap specified in Figure 6C. Insert bar, as shown below, to same depth at 90° intervals and measure clearance between bar and hub face with feeler gauges. The difference in minimum and maximum measurements must not exceed the angular installation limits shown in Figure 6H.

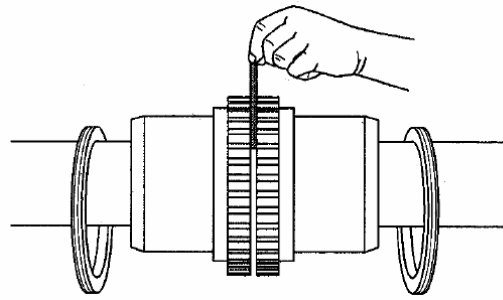

FIGURE 6C – USING SPACER BAR

9. Align so that a straight edge rests within the limits shown in Figure 6D on both hubs as shown below and also at 90° intervals without rotating the coupling. Check with feelers. The clearance must not exceed the PARALLEL OFFSET installation limits specified in Figure 6H.

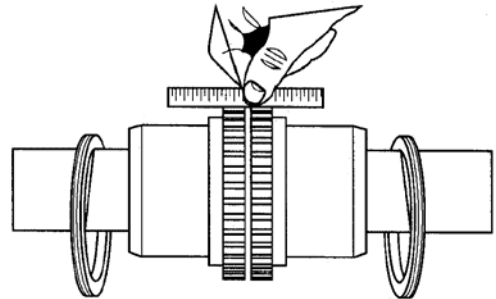

FIGURE 6D – USING STRAIGHT EDGE

10. If adjustment is needed, loosen the motor bolts and add (or remove) an equal amount of shims under each motor foot to align the height. To correct side misalignment, strike the side of the motor foot with a mallet.
11. Tighten the motor bolts and check again. If a correction is made, re-check alignment in all directions. Repeat this process until the desired result is obtained.
12. Pack gap and grooves with coupling vendor supplied grease before inserting grid. When grids are furnished in two or more segments, install them so that all cut ends extend in the same direction as shown below. This will ensure correct grid contact with non-rotating pin in cover halves.
13. Spread the grid slightly to pass over the coupling teeth and seat with a soft mallet.

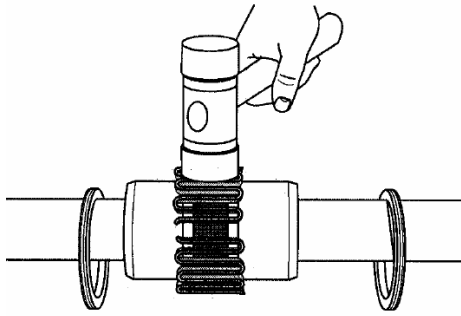

FIGURE 6E – SEATING THE GRID

14. Pack the spaces between and around the grid with as much as coupling vendor supplied grease as possible and wipe off excess flush with the top of the grid.
15. Position seals on hubs to line-up with grooves in cover. Position gaskets on flange of lower cover half and assemble covers so that the match marks are on the same side.

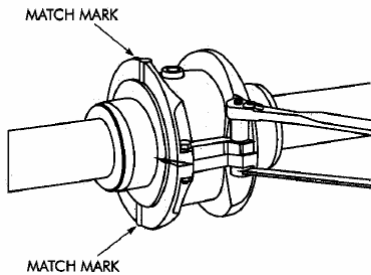
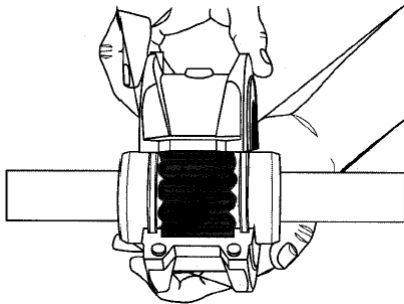

FIGURE 6F – COVER INSTALLATION

16. If the shafts are not horizontal, or coupling is to be used vertically, assemble cover halves with the lug and match mark UP or on the high side. Push gaskets in until they stop against the seals and secure cover halves with fasteners, tightening to torque specified in Figure 6H. Ensure gaskets stay in position during fastener tightening.

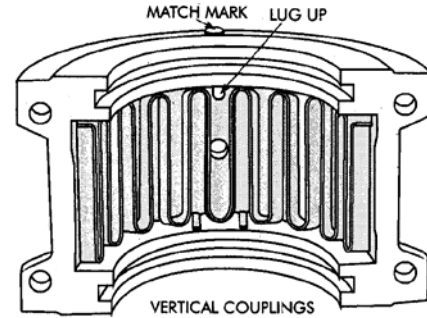

FIGURE 6G – COVER INSTALLATION, VERTICAL POSITION

17. Ensure the lube plugs are installed in the cover.



WARNING: Coupling Failure

Do not operate coupling without proper lubrication

Failure to follow these instructions could result in serious personal injury or death and property damage.

ANGULAR MISALIGNMENT

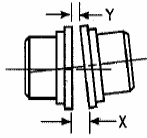

PARALLEL OFFSET MISALIGNMENT

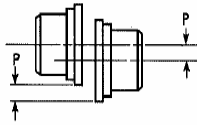

END FLOAT

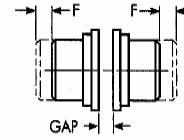

Size	Installation Limits				Fastener Tightening Torque Values			
	Parallel Offset (P)	Angular (x-y)	Hub Gap +/- 10%	End Float Physical Limit (Min) 2xF	Cover Fastener Tightening Torque Values	Flange Type 31 & 35	Maximum Allowable RPM	Lube Wt.
	Max Inch	Max Inch	Inch	Inch	In. Series Fasteners (lb*in)	In. Series Fasteners (lb*in)		lb
1040T	0.006	0.003	0.125	0.211	100	120	3600	0.12
1050T	0.008	0.004	0.125	0.212	200	250	3600	0.15
1060T	0.008	0.005	0.125	0.258	200	440	3600	0.19
1070T	0.008	0.005	0.125	0.259	200	440	1800	0.25
1080T	0.008	0.006	0.125	0.288	200	825	1800	0.38

FIGURE 6H – MISALIGNMENT & FASTENER TORQUE VALUES

Final Alignment

Final alignment cannot be accomplished until the pump has been operated initially for a sufficient length of time to attain operating temperature. When normal operating temperature has been attained, secure the pump to re-check alignment and compensate for temperature accordingly. See Alignment Section.



WARNING: Rotating Components Hazard

Do not operate pump without all guards in place. Failure to follow these instructions could result in serious personal injury or death and property damage.



WARNING: Coupling Failure

Do not operate pump with coupling out of alignment. Ensure final coupling alignment is within the values stated above or according to the coupling manufacturer's instructions. Coupling, pump, or driver failure may occur.

Failure to follow these instructions could result in serious personal injury or death and property damage.

OPTIONAL Alignment Procedure

If desired, the pump and motor feet can be doweled to the base after final alignment is complete. This should not be done until the unit has been run for a sufficient length of time and alignment is within the tolerance. See Doweling Section.



CAUTION: Extreme Temperature and/or Flying Debris Hazard

Eye protection and gloves required. Failure to follow these instructions could result in property damage and/or moderate personal injury.

NOTE: Pump may have been doweled to base at factory.

Provide for pipe expansion when hot fluids are to be pumped.

14. DOWELING

Dowel the pump and driving unit as follows:

- a. Drill holes through diagonally opposite feet and into the base. Holes must be of a diameter 1/64 inch less than the diameter of the dowel pins. Clean out the chips.
- b. Ream the holes in feet and base to the proper diameter for the pins (light push fit). Clean out the chips.
- c. Insert pins to be approximately flush with feet.

15. SUCTION AND DISCHARGE PIPING

General

When installing the pump piping, be sure to observe the following precautions:

Piping should always be run to the pump.

Do not move pump to pipe. This could make final alignment impossible.

Both the suction and discharge piping should be supported independently near the pump and properly aligned, so that no strain is transmitted to the pump when the flange bolts are tightened. Use pipe hangers or other supports at necessary intervals to provide support. When expansion joints are used in the piping system, they must be installed beyond the piping supports closest to the pump. Tie bolts should be used with expansion joints to prevent pipe strain. Do not install expansion joints next to the pump or in any way that would cause a strain on the pump resulting from system pressure changes. It is usually advisable to increase the size of both suction and discharge pipes at the pump connections to decrease the loss of head from friction.

Install piping as straight as possible, avoiding unnecessary bends. Where necessary, use 45-degree or long sweep 90-degree fitting to decrease friction losses.

Make sure that all piping joints are air-tight.

Where flanged joints are used, assure that inside diameters match properly.

Remove burrs and sharp edges when making up joints.

Do not "spring" piping when making any connections.

Suction Piping

When installing the suction piping, observe the following precautions (See Figure 7).

The sizing and installation of the suction piping is extremely important. It must be selected and installed so that pressure losses are minimized and sufficient liquid will flow into the pump when started and operated. Many NPSH (Net Positive Suction Head) problems can be attributed directly to improper suction piping systems.

Friction losses caused by undersized suction piping can increase the fluid's velocity into the pump. As recommended by the Hydraulic Institute Standard ANSI/HI 1.1-1.5-1994, suction pipe velocity should not exceed the velocity in the pump suction nozzle. In some situations pipe velocity may need to be further reduced to satisfy pump NPSH requirements and to control suction line losses. Pipe friction can be reduced by using pipes that are one to two sizes larger than the pump suction nozzle in order to maintain pipe velocities less than 5 feet/second.

Suction piping should be short in length, as direct as possible, and never smaller in diameter than the pump suction opening. If the suction pipe is short, the pipe diameter can be the same size as the suction opening. If longer suction pipe is required, pipes should be one or two sizes larger than the opening depending on piping length.

Suction piping for horizontal double suction pumps should not be installed with an elbow close to the suction flange of the pump except when the suction elbow is in the vertical plane. A suction pipe of the same size as the suction nozzle approaching at any angle other than straight up or straight down must have the elbow located 10 pipe diameters from the suction flange of the pump. Vertical mounted pumps and other space limitations require special piping.

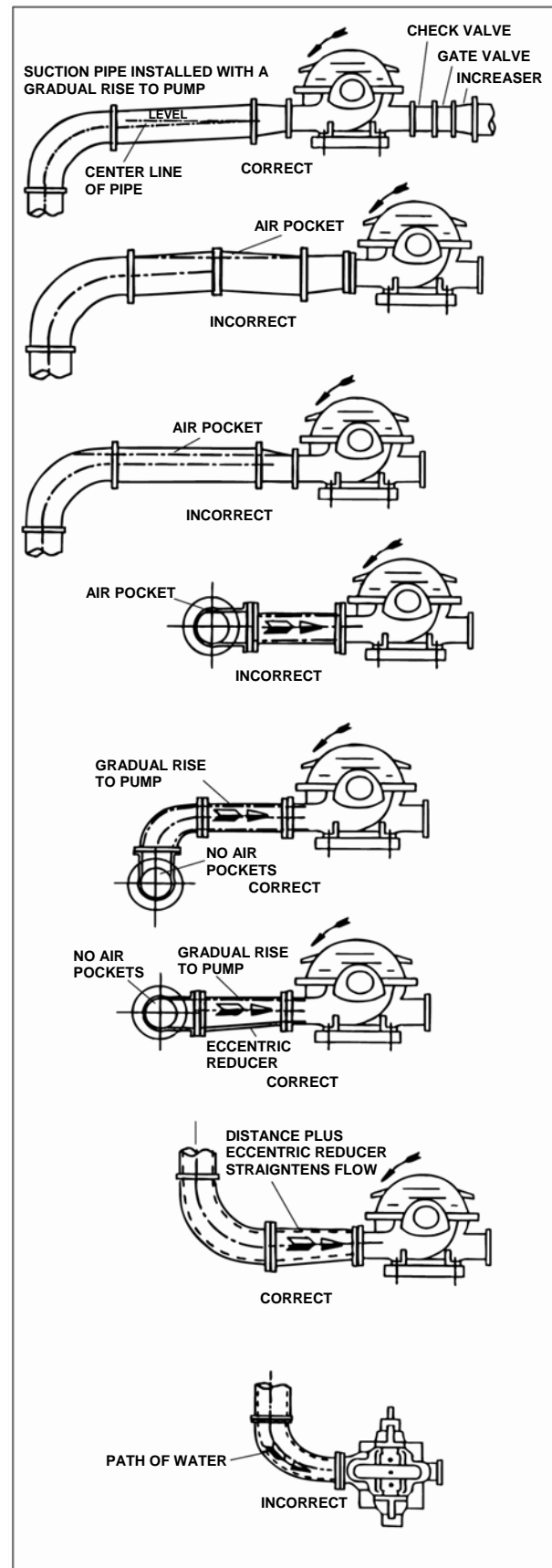

**FIGURE 7 – SUCTION PIPE INSTALLATIONS
(PIPING SUPPORTS NOT SHOWN)**

There is always an uneven turbulent flow around an elbow and when it is in a position other than the vertical it causes more liquid to enter one side of the impeller than the other (See Figure 8). This results in high unequalized thrust loads that will overheat the bearings and cause rapid wear in addition to affecting hydraulic performance.

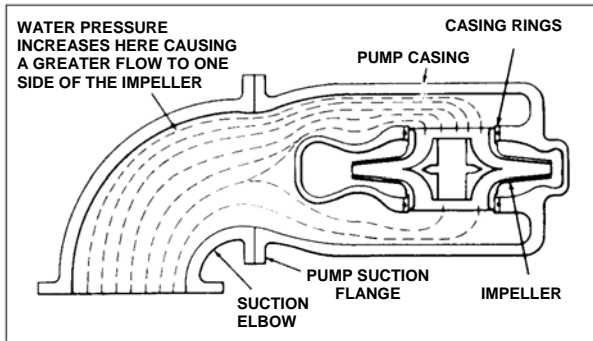

FIGURE 8 - UNBALANCED LOADING OF A DOUBLE SUCTION IMPELLER DUE TO UNEVEN FLOW AROUND ON ELBOW ADJACENT TO THE PUMP.

When operating on a suction lift, the suction pipe should slope upward to the pump nozzle. A horizontal suction line must have a gradual rise to the pump. Any high point in the pipe will become filled with air and thus prevent proper operation on the pump. When reducing the piping to the suction opening diameter use an eccentric reducer with the eccentric side down to avoid air pockets.

NOTE: When operating on suction lift never use a straight taper reducer in a horizontal suction line, as it tends to form an air pocket in the top of the reducer and the pipe.

To facilitate cleaning pump liquid passage without dismantling pump, a short section of pipe (Dutchman or spool piece) so designed that it can be readily dropped out of the line can be installed adjacent to the suction flange. With this arrangement, any matter clogging the impeller is accessible by removing the nozzle (or pipe section).

Valves in Suction Piping

When installing valves in the suction piping, observe the following precautions:

- a. If the pump is operating under static suction lift conditions, a foot valve may be installed in the suction line to avoid the necessity of priming each time the pump is started. This valve should be of the flapper type, rather than the multiple

spring type, sized to avoid excessive friction in the suction line. (Under all other conditions, a check valve, if used, should be installed in the discharge line.) (See "Valves in Discharge Piping" below.)

- b. When foot valves are used, or where there are other possibilities of "water hammer," close the discharge valve slowly before shutting down the pump.
- c. Where two or more pumps are connected to the same suction line, install gate valves so that any pump can be isolated from the line. Gate valves should be installed on the suction side of all pumps with a positive pressure for maintenance purposes. Install gate valves with stems horizontal to avoid air pockets. Globe valves should not be used, particularly where NPSH is critical.
- d. The pump must never be throttled by the use of a valve on the suction side of the pump. Suction valves should be used only to isolate the pump or maintenance purposes, and should always be installed in positions to avoid air pockets.
- e. A pump drain valve should be installed in the suction piping between the isolation valve and the pump.

Discharge Piping

If the discharge piping is short, the pipe diameter can be the same as the discharge opening. If the piping is long, pipe diameter should be one or two sizes larger than the discharge opening. On long horizontal runs, it is desirable to maintain as even a grade as possible. Avoid high spots, such as loops, which will collect air and throttle the system or lead to erratic pumping.

Valves in Discharge Piping

A triple duty valve should be installed in the discharge. The triple duty valve placed on the pump protects the pump from excessive back pressure, and prevents liquid from running back through the pump in case of power failure.

Pressure Gauges

Properly sized pressure gauges should be installed in both the suction and discharge nozzles in the gauge taps (which are provided on request). The gauges will enable the operator to easily observe the operation of the pump, and also determine if the pump

is operating in conformance with the performance curve. If cavitation, vapor binding, or other unstable operation should occur, widely fluctuating discharge pressure will be noted.

Pump Insulation

On chilled water applications most pumps are insulated. As part of this practice, the pump bearing housings should not be insulated since this would tend to “trap” heat inside the housing. This could lead to increased bearing temperatures and premature bearing failures.

16. STUFFING BOX LUBRICATION

Contaminants in the pumped liquid must not enter the stuffing box. These contaminants may cause severe abrasion or corrosion of the shaft, or shaft sleeve, and rapid packing or mechanical seal deterioration; they can even plug the stuffing box flushing and lubrication system. The stuffing box must be supplied at all times with a source of clean, clear liquid to flush and lubricate the packing or seal. It is important to establish the optimum flushing pressure that will keep contaminants from the stuffing box cavity. If this pressure is too low, fluid being pumped may enter the stuffing box. If the pressure is too high, excessive packing or seal wear may result; and extreme heat may develop in the shaft causing higher bearing temperatures. The most desirable condition, therefore, is to use a seal water pressure 15-20 psig above the maximum stuffing box pressure.

17. PACKING

Standard pumps are normally packed before shipment. If the pump is installed within 60 days after shipment, the packing will be in good condition with a sufficient supply of lubrication. If the pump is stored for a longer period, it may be necessary to repack the stuffing box. In all cases, however, inspect the packing before the pump is started.

NOTE: Packing adjustment is covered in the Maintenance section of this manual.

On some applications, it is possible to use internal liquid lubrication (pumped liquid) to lubricate packing. Only when all of the following conditions prevail, can this be done:

1. Liquid is clean, free from sediment and chemical precipitation and is compatible with seal materials.

2. Temperature is above 32°F and below 160°F.
3. Suction pressure is below 75 psig.
4. Lubrication (pumped liquid) has lubricating qualities.
5. Liquid is non-toxic and non-volatile.

When the liquid being pumped contains solids or is otherwise not compatible with packing materials, an outside supply of seal liquid should be furnished. In general, external-injection liquid (from an outside source) is required when any of the above conditions cannot be met.

The standard stuffing box consists of rings of packing (see assembly section for number of rings), a seal cage (optional), and a gland. A shaft sleeve which extends through the box and under the gland is normally provided to protect the shaft.

A tapped hole is supplied in the stuffing box directly over the seal cage to introduce a clean, clear sealing medium. The stuffing box must, at all times, be supplied with sealing liquid at a high enough pressure to keep the box free from foreign matter, which would quickly destroy the packing and score the shaft sleeve.

Only a sufficient volume of sealing liquid to create a definite direction of flow from the stuffing box inward to the pump casing is required, but the pressure is important. Apply seal water at a rate of approximately .25 GPM at a pressure approximately 15 to 20 psig above the suction pressure. (Approximately one (1) drop per second.)

One recommended method to minimize error in regulating flushing water is a “Controlled Pressure System” (Figure 9). It is important to set the pressure reducing valve adjusted to a value slightly exceeding the maximum stuffing box operating pressure (assuming it is reasonably constant). A flow indicating device will detect a failing of the bottom packing rings allowing leakage in the pump.

External sealing liquid should be adjusted to the point where the packing runs only slightly warm, with a very slow drip from the stuffing box. Excess pressure from an external source can be very destructive to packing. More pressure is required, however, for abrasive slurries than for clear liquids. Examination of the leakage will indicate whether to increase or decrease external

pressure. If slurry is present in the leakage, increase the pressure until only clear liquid drips from the box. If the drippage is corrosive or harmful to personnel, it should be collected and piped away.

A common error is to open the external piping valve wide and then control the drippage by tightening the packing gland. A combination of both adjustments is essential to arrive at the optimum condition. The life of packing and sleeve depends on careful control more than any other factor.

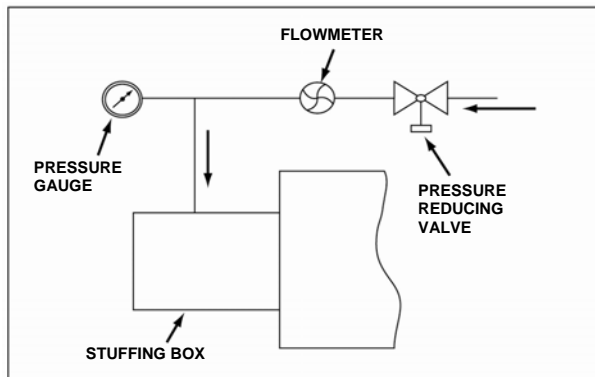

FIGURE 9 – CONTROLLED PRESSURE SYSTEM

OPERATION

**WARNING: Unexpected Startup Hazard**

Disconnect and lockout power before servicing. Failure to follow these instructions could result in serious personal injury or death, or property damage.

**WARNING: Electrical Shock Hazard**

Electrical connections to be made by a qualified electrician in accordance with all applicable codes, ordinances, and good practices. Failure to follow these instructions could result in serious personal injury or death, or property damage.

**WARNING: Rotating Components Hazard**

Do not operate pump without all guards in place. Failure to follow these instructions could result in serious personal injury or death and property damage.

**CAUTION: Seal Damage Hazard**

Do not run pump dry, seal damage may occur. Failure to follow these instructions could result in property damage and/or moderate personal injury.

1. PRE-START CHECKS

Before initial start of the pump, make the following inspections:

- a. Check alignment between pump and motor.
- b. Check all connections to motor and starting device with wiring diagram. Check voltage, phase, and frequency on motor nameplate with line circuit.
- c. Check suction and discharge piping and pressure gauges for proper operation.
- d. Check impeller adjustment, see specific section for proper adjustment.
- e. Turn rotating element by hand to assure that it rotates freely.
- f. Check driver lubrication.
- g. Assure that pump bearings are properly lubricated.
- h. Assure that coupling is properly lubricated, if required.
- i. Assure that pump is full of liquid (See 2. Priming) and all valves are properly set and operational, with the discharge valve closed, and the suction valve open.
- j. Check rotation. Be sure that the drive operates in the direction indicated by the arrow on the pump casing as serious damage can result if the pump is operated with incorrect rotation. Check rotation each time the motor leads have been disconnected.

2. PRIMING

If the pump is installed with a positive head on the suction, it can be primed by opening the suction and vent valve and allowing the liquid to enter the casing.

If the pump is installed with a suction lift, priming must be done by other methods such as foot valves, ejectors, or by manually filling the casing and suction line.

**WARNING: Rotating Components Hazard**

Do not operate pump without all guards in place. Failure to follow these instructions could result in serious personal injury or death and property damage.

3. STARTING

- a. Close drain valves and valve in discharge line.
- b. Open fully all valves in the suction line.
- c. Prime the pump.

NOTE: If the pump does not prime properly, or loses prime during start-up, it should be shutdown and the condition corrected before the procedure is repeated.

- d. When the pump is operating at full speed, open the discharge valve slowly. This should be done promptly after start-up to prevent damage to pump by operating at zero flow.

4. OPERATING CHECKS

- a. Check the pump and piping to assure that there are no leaks.
- b. Check and record pressure gauge readings for future reference.

- c. Check and record voltage, amperage per phase, and kw if an indicating wattmeter is available.
- d. Check bearings for lubrication and temperature. Normal temperature is 180° maximum.
- e. Make all pump output adjustments with the discharge line.



CAUTION: Cavitation Damage Hazard

Do not throttle the suction line to adjust the pump output. Failure to follow these instructions could result in property damage and/or moderate personal injury.

5. FREEZING PROTECTION

Pumps that are shut down during freezing conditions should be protected by one of the following methods.

- a. Drain the pump; remove all liquids from the casing.
- b. Keep fluid moving in the pump and insulate or heat the pump to prevent freezing.



CAUTION: Bearing/Seal Damage Hazard

Do not let heated pump temperature rise above 150°F. Failure to follow these instructions could result in property damage and/or moderate personal injury.

CHANGING ROTATION

9100 Series Centrifugal Fire Pumps can be operated clockwise or counter-clockwise when viewed from the coupling end of the pump. If you wish to reverse the suction and discharge nozzles, this can be accomplished with the same pump as follows:

IMPORTANT: Refer to the disassembly and assembly procedures section of this manual for proper disassembly and assembly techniques:

1. Remove the impeller from the shaft, turn it 180° and replace it on the shaft. (Follow the disassembly procedures given in this manual.)
2. With the rotating element out of the casing, remove the casing from the bedplate and turn 180°.
3. Set the rotating element back in the casing and reassemble the pump.

NOTE: The impeller and casing are in the same relationship to each other as they were originally. The shaft and motor are also in the same relationship to each other as they were originally.

4. Reassemble pump and realign the coupling as called for in the alignment instructions.



WARNING: Rotating Components Hazard

Do not operate pump without all guards in place. Failure to follow these instructions could result in serious personal injury or death and property damage.

5. The rotation of the motor must be changed by switching the motor leads.

NOTE: Unless the motor rotation is reversed, the impeller will run backward.

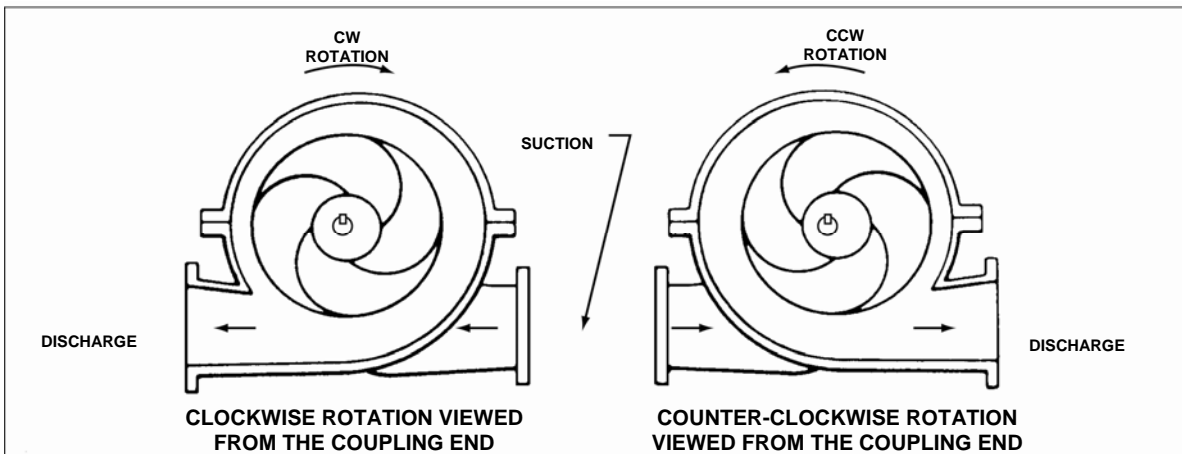

FIGURE 10 - CORRECT RELATIONSHIP OF IMPELLER AND CASING

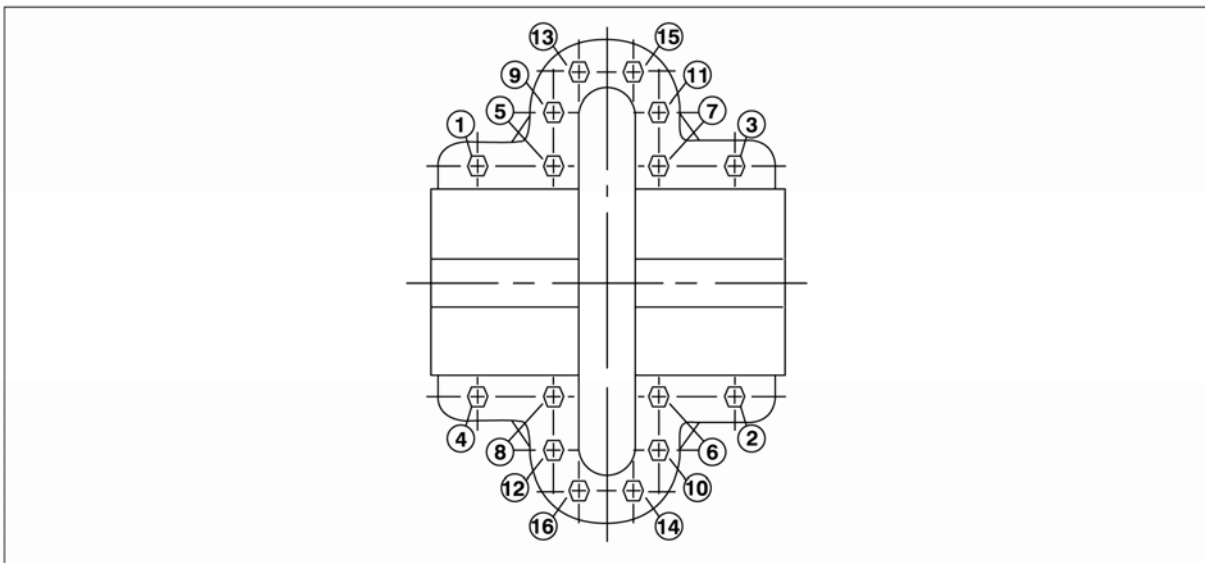

FIGURE 11 - MAIN JOINT BOLTS

TROUBLE SHOOTING

Between regular maintenance inspections, be alert for signs of motor or pump trouble. Common symptoms are listed below. Correct any trouble immediately and AVOID COSTLY REPAIR AND SHUTDOWN.

CAUSES	CURES
No Liquid Delivered	
1. Lack of prime.	Fill pump and suction pipe completely with liquid.
2. Loss of prime.	Check for leaks in suction pipe joints and fittings; vent casing to remove accumulated air.
3. Suction lift too high.	If no obstruction at inlet, check for pipe friction losses. However, static lift may be too great. Measure with mercury column or vacuum gauge while pump operates. If static lift is too high, liquid to be pumped must be raised or pump lowered.
4. Discharge head too high.	Check pipe friction losses. Large piping may correct condition. Check that valves are wide open.
5. Speed too low.	Check whether motor is directly across-the-line and receiving full voltage. Or frequency may be too low; motor may have an open phase.
6. Wrong direction of rotation.	Check motor rotation with directional arrow on pump casing.
7. Impeller completely plugged.	Dismantle pump and clean impeller.
Not Enough Liquid Delivered	
8. Air leaks in suction piping.	If liquid pumped is water or other non-explosive, and explosive gas or dust is not present, test flanges for leakage with flame or match, or by plugging inlet and putting line under pressure. A gauge will indicate a leak with a drop of pressure.
9. Speed too low.	See item 5.
10. Discharge head too high.	See item 4.
11. Suction lift too high.	See item 3.
12. Impeller partially plugged.	See item 7.
13. Cavitation; insufficient NPSH (depending on installation)	a. Increase positive suction head on pump by lowering pump. b. Sub-cool suction piping at inlet to lower entering liquid temperature. c. Pressurization suction vessel.
14. Defective impeller.	Inspect impeller, bearings and shaft. Replace if damaged or vane sections badly eroded.
15. Foot valve too small or partially obstructed	Area through ports of valve should be at least as large as area of suction pipe – preferably 1-1/2 times. If strainer is used, net clear area should be 3 to 4 times area of suction pipe.
16. Suction inlet not immersed deep enough	If inlet cannot be lowered, or if eddies through which air is sucked persist when it is lowered, chain a board to suction pipe. It will be drawn into eddies, smothering the vortex.
17. Wrong direction of rotation.	Symptoms are an overloaded drive and about 1/3 rated capacity from pump. Compare rotation of motor with directional arrow on pump casing.
18. Too small impeller diameter. (Probable cause if none of above.)	Check with factory to see if a larger impeller can be used; otherwise, cut pipe losses or increase speed – or both, as needed. But be careful not to seriously overload drive.
19. Speed too low.	See item 5.
20. Air leaks in suction piping.	See item 8.

CAUSES	CURES
Not Enough Pressure	
21. Mechanical defects.	See item 14 and 15.
22. Obstruction in liquid passages.	Dismantle pump and inspect passages of impeller and casing. Remove obstruction.
23. Air or gases in liquid. (Test in laboratory, reducing pressure on liquid to pressure in suction line. Watch for bubble formation.)	May be possible to over rate pump to point where it will provide adequate pressure despite condition. Better to provide gas separation chamber on suction line near pump, and periodically exhaust accumulated gas. See item 13.
24. Too small impeller diameter. (Probable cause if none above.)	See item 18.
Pump Operates For Short Time, Then Stops	
25. Incomplete priming.	Free pump, piping and valves of all air. If high points in suction line prevent this, they need correcting. See page 20.
26. Suction lift too high.	See item 3.
27. Air leaks in suction piping.	See item 8.
28. Air or gases in liquid.	See item 23.
Pump Takes Too Much Power	
29. Head lower than rating; thereby pumping too much liquid.	Machine impeller's OD to size advised by factory.
30. Cavitation	See item 13.
31. Mechanical defects.	See items 14 and 15.
32. Suction inlet not immersed enough.	See item 16.
33. Liquid heavier (in either viscosity or specific gravity) than allowed for.	Use larger driver. Consult factory for recommended size. Test liquid for viscosity and specific gravity.
34. Wrong direction of rotation.	See item 6.
35. Casing distorted by excessive strains from suction or discharge piping.	Check alignment. Examine pump for friction between impeller and casing. Replace damaged parts.
36. Shaft bent due to damage – through shipment, operation, or overhaul.	Check deflection of rotor by turning on bearing journals. Total indicator run-out should not exceed 0.002 on shaft and 0.004 inch on impeller wearing surface.
37. Mechanical failure of critical pump parts.	Check bearings and impeller for damage. Any irregularity in these parts will cause a drag on shaft.
38. Misalignment.	Realign pump and driver.
39. Speed may be too high (brake hp of pump varies as the cube of the speed; therefore, any increase in speed means considerable increase in power demand).	Check voltage on motor.
40. Electrical defects.	The voltage and frequency of the electrical current may be lower than that for which the motor was built; or there may be defects in motor. The motor may not be ventilated properly due to a poor location.
41. Mechanical defects in turbine, engine or other type of drive exclusive of motor.	If trouble cannot be located, consult factory.

MAINTENANCE

1. GENERAL MAINTENANCE

Operating conditions vary so widely that to recommend one schedule of preventative maintenance for all centrifugal pumps is not possible. Yet some sort of regular inspection must be planned and followed. We suggest a permanent record be kept of the periodic inspections and maintenance performed on your pump. This recognition of maintenance procedure will keep your pump in good working condition, and prevent costly breakdown.

One of the best rules to follow in the proper maintenance of your centrifugal pump is to keep a record of actual operating hours. Then, after a predetermined period of operation has elapsed, the pump should be given a thorough inspection. The length of this operating period will vary with different applications, and can only be determined from experience. New equipment, however, should be examined after a relatively short period of operation. The next inspection period can be lengthened somewhat. This system can be followed until a maximum period of operation is reached which should be considered the operating schedule between inspections.

2. MAINTENANCE OF PUMP DUE TO FLOOD DAMAGE

The servicing of centrifugal pumps after a flooded condition is a comparatively simple matter under normal conditions.

Bearings are a primary concern on pumping units. First, dismantle the bearings; clean and inspect them for any rusted or badly worn surfaces. If bearings are free from rust and wear, reassemble and relubricate them with one of the recommended pump lubricants. Depending on the length of time the pump has remained in the flooded area, it is unlikely that bearing replacement is necessary; however, in the event that rust or worn surfaces appear, it may be necessary to replace the bearings.

Next, inspect the stuffing box, and clean out any foreign matter that might clog the box. Mechanical seals should be cleaned and thoroughly flushed.

Couplings should be dismantled and thoroughly cleaned.

Any pump that is properly sealed at all joints and connected to both the suction and discharge should exclude outside liquid. Therefore, it should not be necessary to go beyond the bearings, stuffing box, and coupling when servicing the pump.

3. BEARING LUBRICATION – GREASE

Grease lubricated ball bearings are packed with grease at the factory and ordinarily will require no attention before starting, provided the pump has been stored in a clean, dry place prior to its first operation. The bearings should be watched the first hour or so after the pump has been started to see that they are operating properly.

The importance of proper lubrication cannot be over emphasized. It is difficult to say how often a bearing should be greased, since that depends on the conditions of operation. It is well to add one ounce of grease at regular intervals, but it is equally important to avoid adding too much grease. For average operating conditions, it is recommended that 1 oz. of grease be added at intervals of three to six months, and only clean grease be used. It is always best if unit can be stopped while grease is added to avoid overloading.

NOTE: Excess grease is the most common cause of over-heating.

A lithium based NLGI-2 grade grease should be used for lubricating bearings where the ambient temperature is above -20°F. Grease lubricated bearings are packed at the factory with Shell Alvania No 2. Other recommended greases are Texaco Multifak No. 2 and Mobilux No. 2 grease.

Greases made from animal or vegetable oils are not recommended due to the danger of deterioration and forming of acid. Do not use graphite. Use of an ISO VG 100 mineral base oil with rust and oxidation inhibitors is recommended.

The maximum desirable operating temperature for ball bearings is 180°F. Should the temperature of the bearing frame rise above 180°F, the pump should be shut down to determine the cause.

4. PACKING SEAL

When a pump with packing is first started it is advisable to have the packing slightly loose without causing an air leak. As the pump runs in, gradually tighten the gland bolts evenly. The gland should never be drawn to the point where packing is compressed too tightly and no leakage occurs. This will cause the packing to burn, score the shaft sleeve and prevent liquid from circulating through the stuffing box cooling the package.

NOTE: Eccentric run-out of the shaft or sleeve through the packing could result in excessive leakage that cannot be compensated for. Correction of this defect requires shaft and/or sleeve replacement. Packing should be checked frequently and replaced as service indicates. Six months might be a reasonable expected life, depending on the operating conditions.

5. CLEANING WITHOUT DISMANTLING PUMP

A short section of pipe so designed that it can be readily dropped out of the line can be installed adjacent to the suction flange. With this arrangement, any matter clogging the impeller is accessible by removing the pipe section.

If the pump cannot be freed of clogging after the above methods have been tried, dismantle the unit as previously described to locate the trouble.

MAINTENANCE TIME TABLE

EVERY MONTH	<p>Check bearing temperature with a thermometer, <u>not by hand</u>. If bearings are running hot (over 180°F), it may be the result of too much lubricant. If changing the lubricant does not correct the condition, disassembly and inspect the bearings. Lip seals bearing on the shaft may also cause the housing to run hot. Lubricate lip seals to correct.</p>
EVERY 3 MONTHS	<p>Check the oil on oil lubricated units. Check grease lubricated bearings for saponification. This condition is usually caused by the infiltration of water or other fluid past the bearing shaft seals and can be noticed immediately upon inspection, since it gives the grease a whitish color. Wash out the bearings with a clean industrial solvent and replace the grease with the proper type as recommended.</p>
EVERY 6 MONTHS	<p>Check the packing and replace if necessary. Use the grade recommended. Be sure the lantern rings are centered in the stuffing box at the entrance of the stuffing box piping connection.</p> <p>Take vibration readings on the bearing housings. Compare the readings with the last set of readings to check for possible pump component failure (e.g. bearings)</p> <p>Check shaft or shaft sleeve for scoring. Scoring accelerates packing wear.</p> <p>Check alignment of pump and motor. Shim up units if necessary. If misalignment reoccurs frequently, inspect the entire piping system. Unbolt piping at suction and discharge flanges to see if it springs away, thereby indicating strain on the casing. Inspect all piping supports for soundness and effective support of load. Correct as necessary.</p>
EVERY YEAR	<p>Remove the upper half of the casing. Inspect the pump thoroughly for wear, and order replacement parts if necessary.</p> <p>Check wear ring clearances. Replace when clearances become three (3) times their normal clearance or when a significant decrease in discharge pressure for the same flow rate is observed. See Engineering Data Section for standard clearances.</p> <p>Remove any deposit or scaling. Clean out stuffing box piping.</p> <p>Measure total dynamic suction and discharge head as a test of pump performance and pipe condition. Record the figures and compare them with the figures of the last test. This is important, especially where the fluid being pumped tends to form a deposit on internal surfaces. Inspect foot valves and check valves, especially the check valve which safeguards against water hammer when the pump stops. A faulty foot or check valve will reflect also in poor performance of the pump while in operation.</p>

NOTE: *The above time table is based on the assumption that after start-up, the unit had been constantly monitored and such a schedule was found to be consistent with operation, as shown by stable readings. Extreme or unusual applications or conditions should be taken into consideration when establishing the maintenance intervals.*

SERVICE INSTRUCTIONS

DISASSEMBLY AND REASSEMBLY PROCEDURES

The procedures outlined in this section cover the dismantling and reassembly of the 9100 Series Centrifugal Fire Pumps.

When working on the pump, use accepted mechanical practices to avoid unnecessary damage to parts. Check clearances and conditions of parts when pump is dismantled and replace if necessary. Steps should usually be taken to restore impeller and casing ring clearance when it exceeds three times the original clearance.

DISMANTLING (PUMP WITH PACKING)



WARNING: Unexpected Startup Hazard

Disconnect and lockout power before servicing. Failure to follow these instructions could result in serious personal injury or death, or property damage.



WARNING: Electrical Shock Hazard

Electrical connections to be made by a qualified electrician in accordance with all applicable codes, ordinances, and good practices. Failure to follow these instructions could result in serious personal injury or death, or property damage.



WARNING:

Prior to working on pump the power source should be disconnected with lockout provisions so power cannot be re-energized to the motor. Close isolating suction and discharge valves. Failure to follow these instructions could result in property damage, severe personal injury, or death.

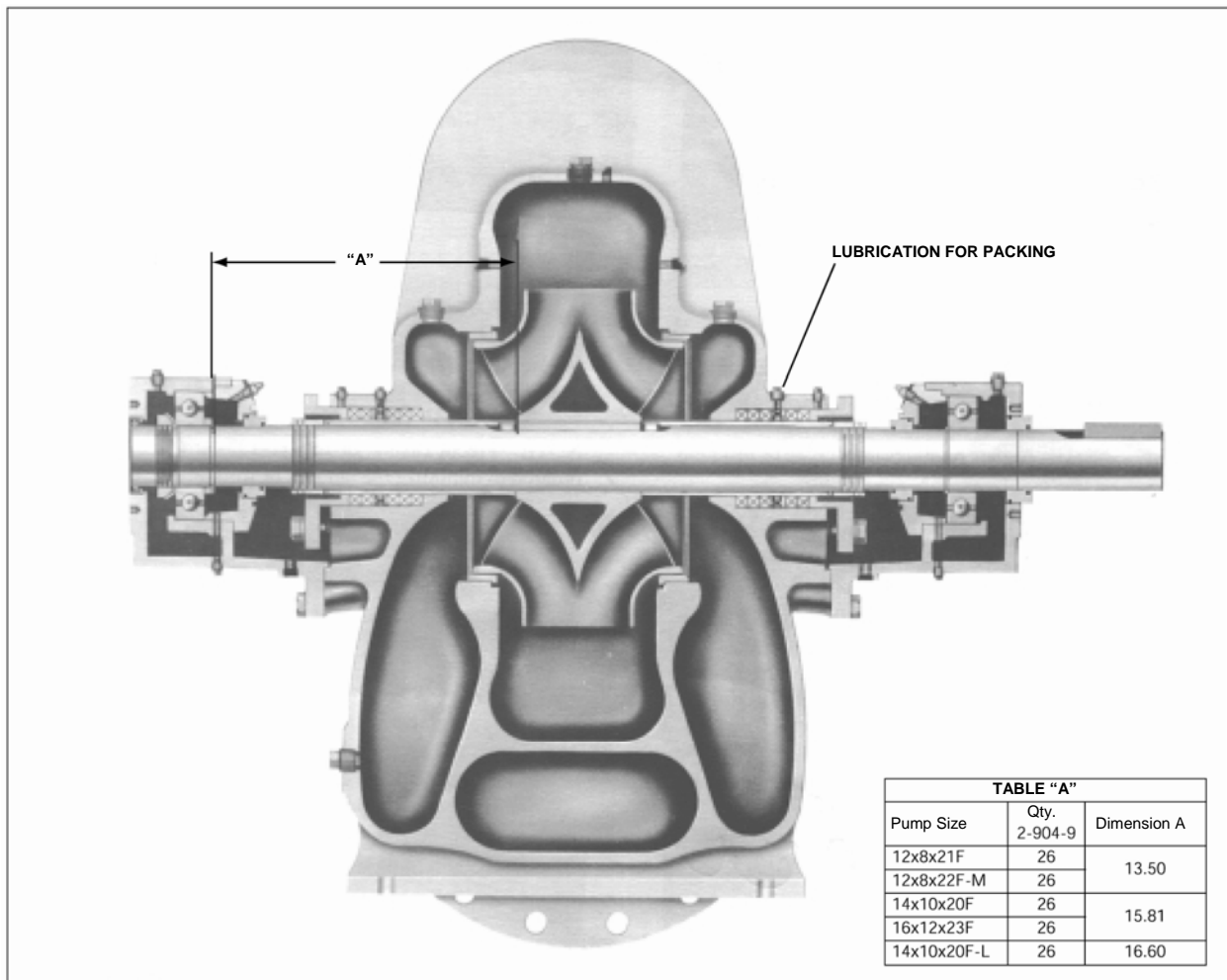

FIGURE 12 - ASSEMBLY SECTION: PUMP WITH PACKING

**CAUTION: Extreme Temperature Hazard**

Allow pump temperatures to reach acceptable levels before proceeding. Open drain valve, do not proceed until liquid stops coming out of drain valve. If liquid does not stop flowing from drain valve, isolation valves are not sealing and should be repaired before proceeding. After liquid stops flowing from drain valve, leave valve open and continue. Remove the drain plug located on the bottom of the pump housing. Do not reinstall plug or close drain valve until reassembly is completed. Failure to follow these instructions could result in property damage and/or moderate personal injury.

(See Appendix "A" for exploded view.)

1. Close valves on suction and discharge sides of pump. If no valves have been installed, it will be necessary to drain the system.
2. Remove the coupler guard. Refer to section titled "Hex Coupler Guard Removal/Installation."
3. Loosen the capscrews which secure the coupler flanges to the coupler hubs. Remove the coupler flanges and sleeve by compressing the flanges and pulling out from beneath the hubs back on the shafts. Remove the coupler hub from the pump shaft.
4. Drain the pump by opening vent plug (0-910-0) and remove drain plugs (0-910-0) on suction and discharge nozzle.
5. Remove seal line (0-910-0, 0-950-0, 0-952-0), if supplied.
6. Remove gland bolts (3-904-9), washers (1-909-9) and slide gland (3-014-2) away from casing.
7. Remove all casing main joint cap screws (2-904-1) and dowels (2-916-9). Use slot in casing main joint and separate the casing halves with a pry bar. Lift upper half casing (2-001-7) by cast lugs.
8. Remove packing (1-924-9) and seal cage (1-013-2) from each stuffing box.
9. Remove cap screws (1-904-9) which hold bearing housings (3-025-2) to the casing and lift rotating element out of lower casing (2-001-08). Rotating element may now be moved to a suitable working location.

10. Pull coupling half and key (3-911-2) off shaft (3-007-0).

NOTE: A spare rotating element can be installed at this point.

11. Remove cap screws (3-904-9) from bearing covers (3-01803, -4).
12. Remove bearing housings (3-025-2), locknut (3-516-4), and lockwasher (3-517-4). Mount bearing puller and remove bearings (3-026-2). Remove thrust washer (3-078-9) and snap ring (3-915-9).

NOTE: Locknut, lockwasher, and thrust washer are not used on inboard bearing.

13. Remove bearing covers (3-018-3, -4) and push bearing isolators (1-333-1) out of bearing covers and coupling end bearing housing (1-332-1, 1-333-1).

**CAUTION:**

DO NOT REUSE THE BALL BEARINGS.

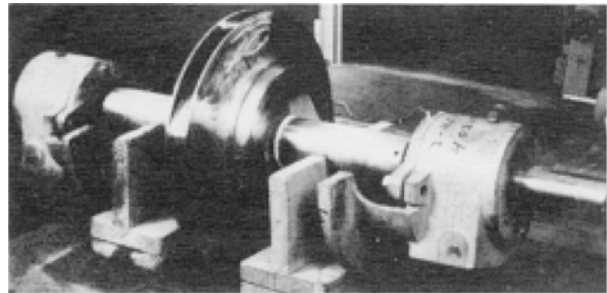

FIGURE 13 - COMPLETE ROTATING ELEMENT LESS PACKING AND GLAND

14. Remove casing rings (3-003-9) from impeller (4-002-0).
15. Remove set screw (3-902-9) from shaft nuts. Remove shaft nuts (3-015-9), O-rings (3-914-9), sleeves (3-009-9) sleeve gaskets (1-428-1) and impeller (4-002-0).

NOTE: Apply heat uniformly to the shaft sleeve to loosen the sealant between the shaft and sleeve. **DO NOT HEAT ABOVE 275°F.** To further assist in removing the sleeves, hold the shaft vertically and drop it on a block of wood. The impeller weight should force both the impeller and sleeve from the shaft.

ASSEMBLY (PUMP WITH PACKING)

All bearings, O-rings, bearing isolators, gaskets, impeller rings, and casing wear rings should be replaced with new parts during assembly. All reusable parts should be cleaned of all foreign matter before reassembling. The main casing joint gasket can be made using the upper or lower half as a template. Lay the gasket material on the casing joint and mark it by pressing it against the edges of the casing. Trim the gasket, so that it is flush with the inside edges of the casing.

1. Place impeller key (3-911-1) in shaft (3-007-0).
2. Check the impeller (4-002-0) and casing to determine the correct impeller rotation (See Figure 10) and locate the impeller on the shaft per dimension "A". (See Figure 12)
3. Place both shaft sleeve keys (3-911-3) on shaft (3-007-0).
4. Slide sleeve gaskets (1-428-1) onto shaft and against hubs of impeller.
5. Slide sleeves (3-009-9) onto shaft.

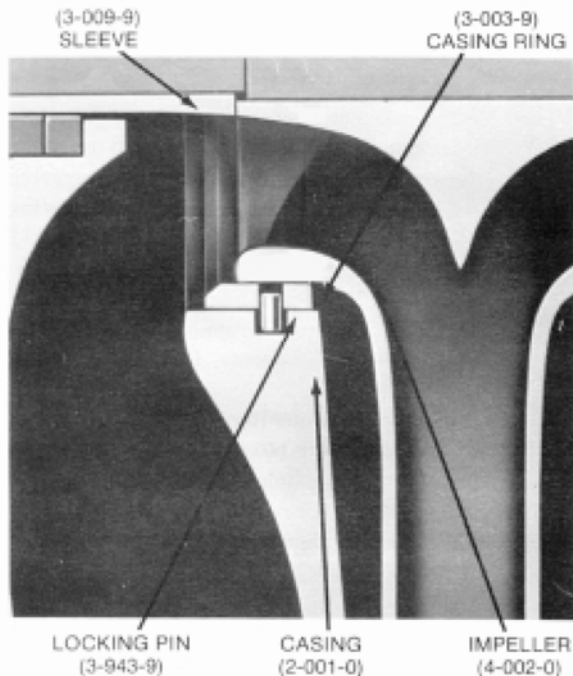

FIGURE 14 - CASING RINGS

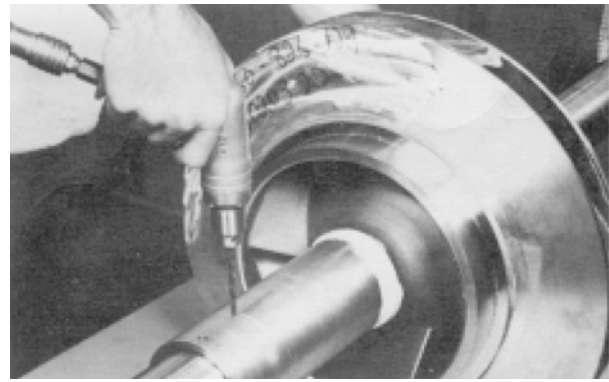

FIGURE 15 - DRILLING SET SCREW RECESS

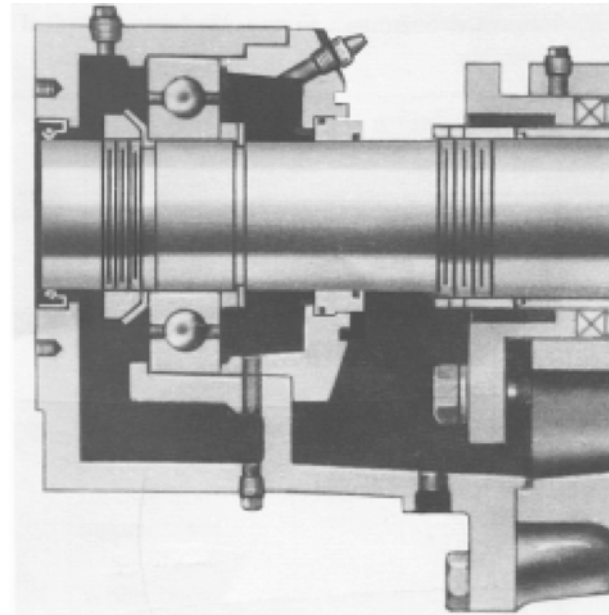

FIGURE 16 - GREASE LUBRICATED BEARING HOUSING

6. Place the sleeve O-ring (3-914-9) onto the shaft, into the sleeve counterbore. Verify that Dimension "A" (Figure 12) is maintained, then using a pin spanner wrench and hammer, securely tighten the shaft sleeve nuts (3-015-9). Then, drill a shallow recess in the shaft through the set screw hole in each of the shaft sleeve nuts. Lock each shaft sleeve nut in position with cup point set screws (3-902-9). (See Figure 15) A low strength sealant, such as Loctite 271, can be used to retain set screws.
7. Assemble casing rings (3-003-9).
8. Start heating bearings (3-026-2) so that they will be ready when called for in step 11. Use dry heat from induction heat lamps from electric furnace, or a 10-15% soluble oil and water solution.



CAUTION:
DO NOT EXCEED 275°F.



CAUTION:
These are precision, high quality bearings. Exercise care at all times to keep them clean and free from foreign matter.

9. Press bearing isolators (1-333-1) in each bearing cover. (See Figure 16) Install gaskets (3-409-9) on each bearing cover.
10. Slide bearing covers (3-018-3, -4) on the shaft. Install snap rings (3-915-9). Install thrust washer (3-078-9) on the outboard end.

For ease of assembly and protection of rubber parts while sliding rubber parts onto shaft, cover O-ring groove, keyways, and threads with electric tape.

NOTE: Inboard bearing cover (3-018-3) is approximately 1/4 inch less in width than the outboard bearing cover (3-018-4). This is the only dimensional difference.

11. Press heated bearing (3-026-2) on shaft against snap ring or thrust washer. Install locknut (3-516-4) and lockwasher (3-517-4) on outboard end. Make certain locknut is secured and then bend over tab on lockwasher.

PUMPS WITH GREASE LUBRICATION

12. Cool bearings at room temperature and coat with 2 or 3 ounces of a recommended grease.
13. Press bearing isolator (1-333-1) in inboard bearing housing and install oil seal (3-177-4) in outboard bearing housing.
14. Slide bearing housings (3-025-2) onto shaft (3-007-0) over bearings (3-0262).
15. Assemble bearing cover to bearing housing with two cap screws (3-904-9).
16. Replace pump coupling half and key (3-911-2).
17. Assemble rotating element in lower half casing (2-001-8). Correctly locate casing ring pins (3-943-9) in casing main joint slot.

NOTE: Sliding inboard bearing housing toward coupling prior to assembling rotating element in casing will ease assembly.

18. Bolt outboard bearing housing in place. Be sure that both housing are seated properly in lower half casing.
19. Bolt inboard bearing housing in place.
20. Clean the gasket surfaces of the casing. Apply Scotch 3M-77 spray adhesive or equivalent to the lower half of the casing.
21. Within one minute of spraying, set the gaskets (2-123-5, -6) in place on the lower half casing, align the holes in the gaskets with the holes in the casing and press the gaskets firmly against the lower half casing face in the area coated by the adhesive.
22. Lower upper half casing (2-001-7) into place (See Figure 17) and locate using the taper dowels (2-916-9) and install casing main joint bolts (2-904-9). The casing joint bolts should be tightened to the following torques: 300 ft-lb minimum for .75"-10 Ferry Cap Counter-bore screws (Grade 8), 400 ft-lb minimum for 1.0"-8 Ferry Cap Counter-bore screws (Grade 8). Bolt torquing pattern is shown in Figure 11. Before tightening bolts, be sure taper dowels are seated properly in reamed holes.



CAUTION:
Double check rotation of pump before installing the upper half casing. (Refer to figure 10)

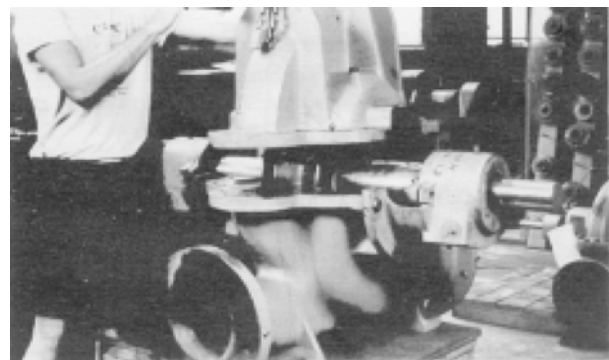

FIGURE 17 - LOWERING CASING COVER ONTO LOWER HALF

NOTE: Torque values are essential in obtaining proper gasket compression so no leakage can occur at main joint.

23. Rotate shaft by hand to assure that it turns smoothly and is free from rubbing and binding.
24. Cut full rings of 5/8 inch square packing so that ends butt, leaving no gap between

packing and casing. Install three rings of packing (1-924-9) and tap fully to bottom of both stuffing boxes. (See Figure 18) Stagger joints of each ring of packing at least 90°. Install seal cage (1-013-2) and be sure that it will line up with seal water inlet when packing is compressed. Install remaining three rings of packing with joints staggered. Assemble glands (1-014-2) square with stuffing box and pull up tight. Then loosen gland bolts (1-904-9) to permit packing to expand, and retighten finger tight. Final adjustment of gland bolts must be done when pump is running. Allow 30 minutes between adjustments. (See Figure 19)

25. Assemble seal water lines (0-901-0, 0-950-0, 0-952-0) to stuffing box and casing. Seal water lines go to inside holes. (See Figure 12)

26. Check coupling alignment and redowel if necessary.



FIGURE 18 - INSERTING PACKING INTO STUFFING BOX



FIGURE 19 - SECURING PACKING GLAND IN POSITION

APPENDIX "A"

EXPLODED VIEW

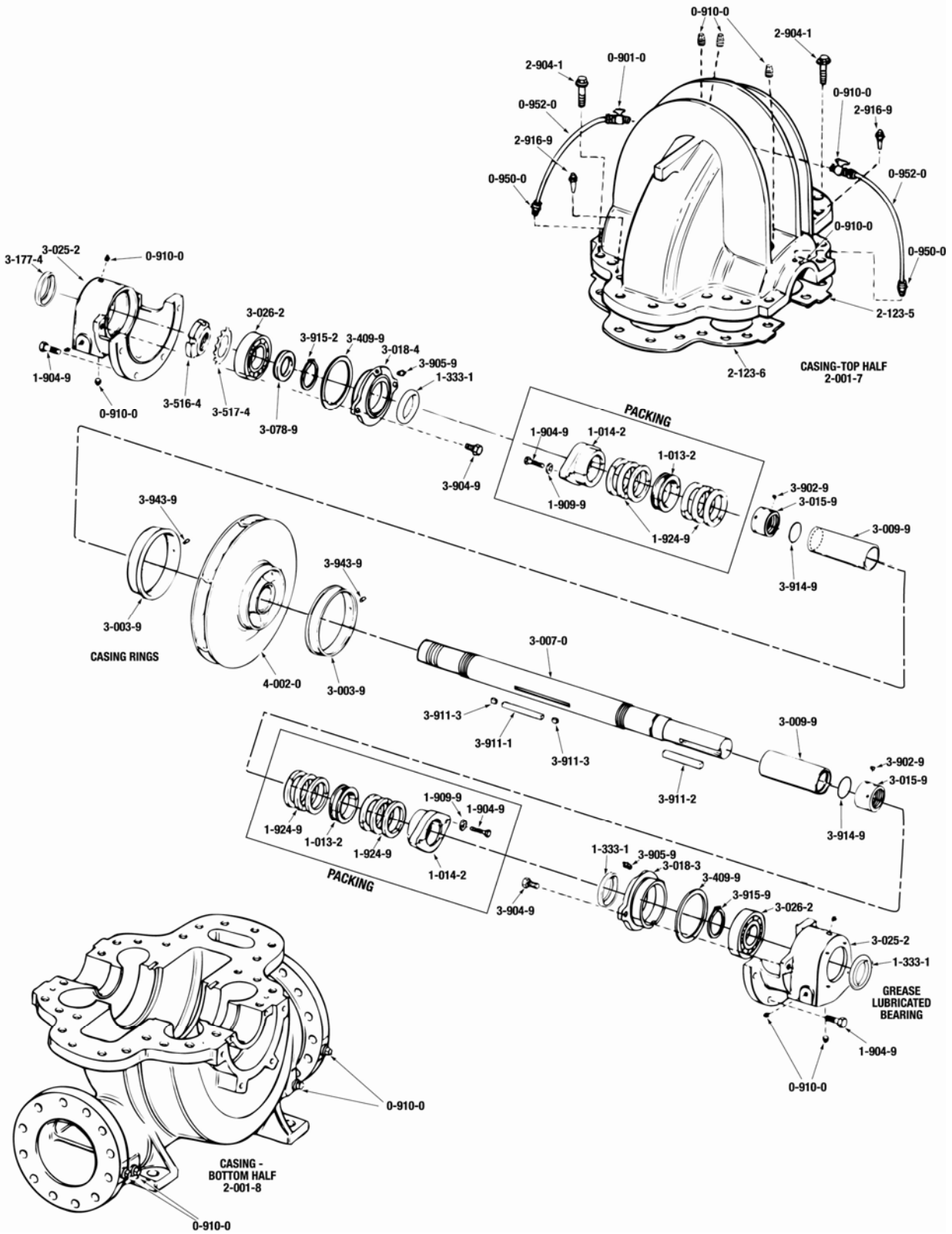

APPENDIX “A”

REPLACEMENT PARTS LIST

PART NUMBER	PART NAME	QUANTITY
		PACKING
0-901-0	Valve	2 (optional)
0-910-0	Pipe Plug	20
0-950-0	Pipe Nipple	2 (optional)
0-952-0	Tubing	2 (optional)
1-013-2	Seal Cage	2
0-014-2	Gland (Packing)	2
1-333-1*	Bearing Isolator	3
1-904-9	Gland and Housing Bolt	12
1-909-9	Washer, Gland Bolt	4
1-924-9*	Packing Ring	12
2-001-7	Casing, Upper Half	1
2-001-8	Casing, Lower Half	1
2-123-5*	Casing Joint Gasket (Suction)	1
2-123-6*	Casing Joint Gasket (Discharge)	1
2-904-1	Cap Screw (Casing)	Varies with pump size
2-916-9	Taper Pin	2
3-003-9*	Casing Ring	2
3-007-0	Shaft	1
3-009-9*	Shaft Sleeve	2
3-015-9	Shaft Sleeve Nut	2
3-018-3	Bearing Housing Cover (Inboard)	1
3-018-4	Bearing Cover (Outboard)	1
3-025-2	Bearing Housing	2
3-026-2*	Bearing	2
3-078-9	Thrust Washer (Outboard)	1
3-177-4*	Lip Seal (Outboard Bearing)	1
3-409-9	Gasket (Bearing Housing Cover)	2
3-516-4	Locknut	1
3-517-4	Lockwasher	1
3-902-9	Set Screw (Shaft Sleeve Nut)	2
3-904-9	Gland and Cover Bolt	4
3-911-1	Key (Impeller)	1
3-911-2	Key (Coupling)	1
3-911-3	Key (Shaft Sleeve)	2
3-914-9*	O-Ring (Shaft Sleeve)	2
3-915-9	Snap Ring	2
3-943-9	Spirol Ring	2
4-002-0	Impeller	1

* Recommended spare parts.

LIMITED END FLOAT COUPLINGS

For units with drivers having sleeve bearings the coupling halves are set to limit total shaft axial movement to less than one-half of the motor rotor assembly end float. This is accomplished by inserting a phenolic disc, or equivalent, of a specified thickness between the motor and pump shaft (See Figure 20).

Some 9100 Fire Pump installations may use the all metal, gear type coupling. Where limited end float gear type couplings are used, the coupling hubs are slip-fit onto the pump and motor shafts. After installation of the coupling covers and hubs; with the motor set on its Magnetic Center, butt the pump and motor shafts with the phenolic disc inserted between them. (The pump thrust bearing limits end float toward the pump, and the coupling covers limit end float towards the motor.) The thrust bearing of the pump is large enough to carry any magnetic thrust developed by the motor when aligned properly.

Once the above instructions have been followed out completely, the **Alignment Procedures** starting on page 9 should then be followed.

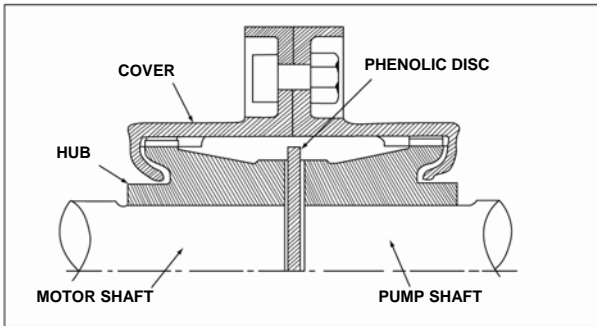

FIGURE 20 - LIMITED END FLOAT COUPLING ARRANGEMENT

ORDERING PARTS

The pumps covered by this manual have been designed and built with certain replaceable wearing parts. The recommended inventory of spare parts depends upon the installation and the importance of continued operation.

For critical service requiring a minimum of “down time” a complete or “quick change” rotating element is recommended.

For normal service, with repairs to be made in the field, the following parts are recommended for stock.

- 1 set of bearings
- 1 set of wearing rings
- 1 set of gaskets, “O” rings and grease seals
- 2 mechanical seals (complete)
- or
- 2 sets of packing (if provided)
- 1 set of shaft sleeves (if provided)

Parts should be ordered as far in advance of their use as possible since circumstances beyond the control of the company may reduce existing stock. Not all parts are stocked and must be manufactured for each order.

To facilitate rapid handling of your order for spare parts, be sure to include the following information:

1. Serial number of the pump.
2. Catalog number of the part.
3. Quantity of each part.
4. Name of the part.
5. Material desired. (Parts will be furnished in original materials unless specified as a material change. All material substitutions should be discussed with the factory.)

CAPSCREW TYPE	HEAD MARKING	CAPSCREW TORQUE (FOOT-POUND)								
		CAPSCREW DIAMETER								
		1/4	5/16	3/8	7/16	1/2	5/8	3/4	7/8	1
SAE Grade 2		6	13	25	38	60	120	190	210	300
Brass Stainless Steel		4	10	17	27	42	83	130	200	300
SAE Grade 5		10	20	35	60	90	180	325	525	800
SAE Grade 8		13	28	46	75	115	225	370	590	895

DEALER SERVICING

If trouble occurs that cannot be rectified, contact your local A-C Fire Pump Systems Representative. They will need the following information in order to give you assistance.

1. Complete nameplate data of pump and motor.
2. Suction and discharge pipe pressure gauge readings.
3. Ampere draw of the motor.
4. A sketch of the pumping hook-up and piping.



© COPYRIGHT 2008
BY ITT CORPORATION
PRINTED IN U.S.A. 4/08

THE ITT ENGINEERED BLOCKS SYMBOL AND
ENGINEERED FOR LIFE ARE REGISTERED
TRADEMARKS OF ITT CORPORATION

ITT
8200 N. Austin Avenue
Morton Grove, IL 60053
Phone: (847) 966-3700
Fax: (847) 966-1914
www.acfirepump.com



CANADA
ITT R&CW Canada
55 Royal Road
Guelph, Ontario,
N1H 1T1, Canada
Phone: (519) 821-1900
www.ittfpc.ca