

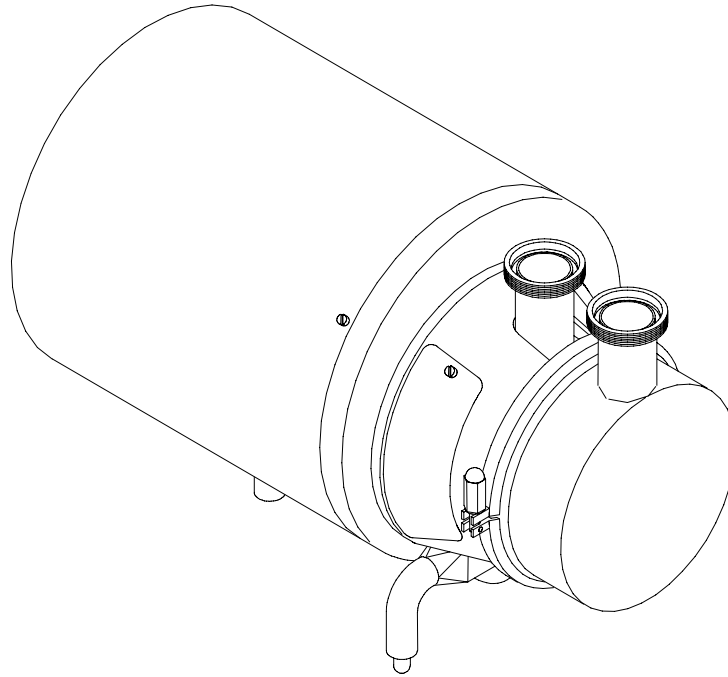

## INSTALLATION, SERVICE AND, MAINTENANCE INSTRUCTIONS

# ASPIR



### **INOXPA, S.A.**

c/Telers, 54 Apto. 174

E-17820 Banyoles

Girona (Spain)

Tel. : (34) 972 - 57 52 00

Fax. : (34) 972 - 57 55 02

Email: [inoxpa@inoxpa.com](mailto:inoxpa@inoxpa.com)

[www.inoxpa.com](http://www.inoxpa.com)





## EC DECLARATION OF CONFORMITY

(according to Directive 98/37/CE, annex II, part A)

Manufacturer: INOXPA, S.A.  
C/ Telers, 54  
17820 Banyoles (Girona) - SPAIN

Hereby declares, that the product:

<u>SELF-PRIMING PUMP</u>	<u>ASPIR A</u>	<u>2008</u>
Name	Type	Year of manufacture

conforms to the specifications of the Council Directive:

**Machine Directive** 98/37/CE, and complies with the essential requirements of the Directive and Harmonised Standards:

UNE-EN ISO 12100-1/2:2003  
UNE-EN 1050:1996  
UNE-EN 809/AC:2001  
UNE-EN 294/AC:1993  
UNE-EN 953:1997  
UNE-EN 563/A1/AC:2000

**Low Voltage Directive** 2006/95/EC (what repeal 73/23/CEE Directive), and are conforms with UNE-EN 60204-1:1997 and UNE-EN 60034-1/A11:2002

**EMC Directive** 2004/108/EC (what repeal 89/336/CEE Directive), and are conforms with UNE-EN 60034-1/A11:2002

In compliance with the Regulations (CE) n° 1935/2004, relating to materials and articles intended to come into contact with foodstuff (repeal Directive 89/109/CEE), the materials in contact with the product do not transfer their components in quantities which may jeopardise consumer's health or safety

**Declaration of Incorporation** (Directive 98/37/CE, annex II, part B):

**The equipments above mentioned won't put to operation till the machine into or onto it will be installed must comply with the stipulations of the Machine Directive.**

Banyoles, February 2008

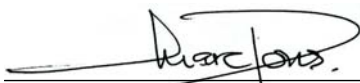
  
Marc Pons Bague Technical Manager

# 1. Introduction

## CHECK THE SHIPMENT.

The first thing to do when the pump is received is to check it and ensure that the contents conform to the shipping voucher. INOXPA inspects all equipment prior to shipment, but it cannot guarantee that the merchandise reaches the user intact. Therefore, the pump and any other article received should be checked and in the event the item in question did not conform to specifications and/or was missing a/some part(s), the transportation company should prepare a report as soon as possible. Each pump bears a serial number engraved on the plate. Indicate the serial number on all documents and correspondence.

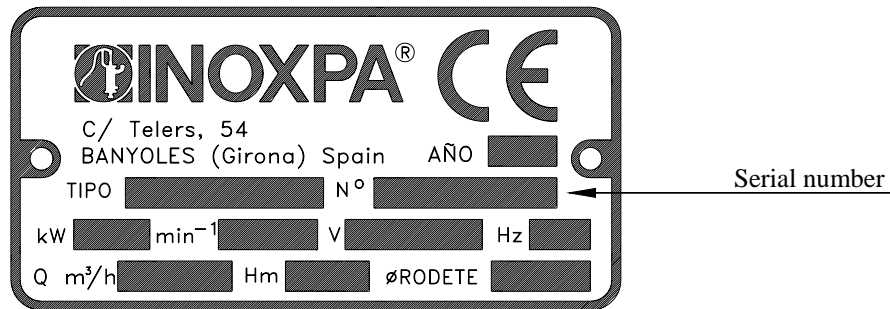

Figure 1.1: Serial number engraved on the manufacturer's plate

If the pump is not put into service upon arrival, a complete revolution of the shaft should be made once a week.

## INSTRUCTIONS MANUAL.

The information provided in the instruction manual refers to updated data.

We reserve the right to modify the design and/or manufacturing specifications of our products as required, devoid of any obligation on our part to adapt any product supplied prior to such alteration.

The technical information made available in this instruction manual, together with the graphs and technical specifications provided, shall continue to belong to us and should not be used (except for starting up this installation), copied, photocopied, made available or otherwise given to third parties without our prior written consent.

INOXPA is reservation the right to modifying this instructions manual without previous notice.

## START-UP INSTRUCTIONS.

This instruction manual contains vital and useful information for properly operating the pump and for keeping it in good running condition. It also contains important instructions for avoiding possible accidents and serious damage that could be produced prior to its start-up and during its installation, thereby ensuring its handling in the safest way possible. Please read the instructions carefully before operating the pump and familiarize yourself with its operation, following very carefully the instructions provided. We wish to stress the importance of being informed on how to perform the installation correctly. It is extremely important to keep these instructions in a secure place close to the installation.

## MAINTENANCE.

This pump, like any other machine, requires routine maintenance. Chapter 9, "Spare Parts", deals with the identification of the spare parts. It is intended for the use of technical and maintenance personnel and for those persons responsible for supplying spare parts.

## OPERATING PRINCIPLES.

### A. Safety.



This symbol indicates those safety instructions contained in this manual which when not followed could jeopardize your safety



This symbol indicates potential problems with electrical safety.



This symbol indicates a compulsory measure to be taken by the user in compliance with specific instructions which serve to guarantee operating safety and/or protection of the pump.

## B. Technical principles.

Quantity	Symbol	Unit
Dinamic viscosity	$\mu$	mPa.s (=cP=Centipoise)
Kinematic viscosity	$V=\mu/\rho$	with $\rho$ =specific weight [Kg/dm <sup>3</sup> ] and $V$ = kinematic viscosity [mm <sup>2</sup> /s] = cSt = Centistoke
	Only the dynamic viscosity is used in this manual.	
Pressure	$p$	[bar]
	$\Delta p$	[bar] - differential pressure
	$P_m$	[bar] - maximum pressure at discharge mouth (design pressure)
Unless otherwise indicated, in this manual pressure is understood to be relative pressure.		
Net positive suction head (NPSH)	NPSH [m]	
	<p>In this manual, NPSH = NPSHr (NPSH required for the pump).  <b>NPSHr</b> = the net pressure above the liquid vapour pressure at pumping temperature and at the pump inlet connection required to avoid performance impairment due to cavitation at rated capacity. NPSHr is measured at the suction flange at the point where the capacity drop = 4% of the rated capacity, and is corrected to the datum elevation.  <b>NPSHa</b> = the total suction pressure available from the system at the pump suction connection, minus the vapour pressure if the liquid at pumping temperature. NPSH available is calculated for the installation. It is the responsibility of the user to determine this value.</p> <p style="text-align: center;"><b><math>NPSHa \geq NPSHr + 0,5</math></b></p>	

### Symbols.

It is absolutely necessary to place symbols on the pump, e.g., arrows which indicate the direction of rotation or other symbols indicating connections to fluids. All of these symbols should be clearly visible and legible.

### Training and experience.

The personnel who are responsible for the operation, maintenance, inspection and assembly of the equipment should have the proper experience and training. The scope of their responsibilities and the supervision of the operators should be specifically defined by the plant foreman.

If the operators did not have the required knowledge, they should be trained, which could be done by the manufacturer of the machine or by the supplier on behalf of the shop foreman.

Furthermore, the shop foreman should make sure that the contents of the instruction manual are fully understood by the operators.

### In accordance with the instructions.

Any failure to comply with the instructions could lead to a hazard for the operators, the atmospheric conditions of the room, and the machine, and it could lead to a loss to any right to make a claim for damages.

Such non-compliance could bring with it the following risks:

- Important operating failures of the machine / plant.
- Failure to comply with specific maintenance and repair procedures.
- Potential electrical, mechanical and chemical hazards.
- Atmospheric conditions in the room could be hazardous due to the release of chemical substances.

### In accordance with the regulations governing safety at work.

The instructions contained in this manual should be followed for operating the pump, along with national regulations and any other service and safety instructions made available by the shop foreman, so as to avoid accidents.

### Safety instructions for handling.

If the machine's components, whether in a cold or warm state, constitute some hazard, then accidental contact with the same should be avoided.

When the machine is operating, be sure that the rotating parts are protected by a shield.

In the event of a fire (e.g., mechanical seal) of hazardous fluids (e.g., explosives, toxic agents, hot products), the machine should be emptied to prevent any risk to persons or to the ambient conditions. Existing regulations should be strictly adhered to. Avoid any hazard which could be produced by the electrical circuits (e.g.: VDE specifications and regulations on the supply of local energy services).

### Safety instructions for maintenance, inspection and assembly.

It is the shop foreman's responsibility to see to it that maintenance, inspection and assembly work is performed by qualified personnel once they have become familiar with the subject; they should read this manual very carefully.

Work should only be done on this machine when it is stopped; it is extremely important that the procedure for stopping the machine be followed as set forth in this manual.

Those pumps should be de-contaminated which may contain hazardous agents.

Upon completion of the work, re-install the safety and protection devices.

Prior to re-initiating the operation of the machine, the instructions given in the chapter on "Operating Principles" should be read.

#### **Changes without prior authorization and production of spare parts.**

No modification can be made to the machine without the prior consent of the manufacturer. For your safety, use spare parts and accessories authorized by the manufacturer.

The use of other parts exempts the manufacturer from any and all responsibility.

#### **Unauthorized operations.**

The machine's safety is only ensured if it is used properly in accordance with the instructions given in this manual.



**The limits for values specified in the data sheet cannot be exceeded under any circumstances.**

Any change in operating conditions can only be done with the prior written consent of INOXPA.

#### **WARRANTY.**

We wish to point out that any warranty issued will be null and void and that we are entitled to an indemnity for any civil liability claim for products which might be filed by third parties if:

- operation and maintenance work has not been done following the corresponding instructions; the repairs have not been made by our personnel or have been made without our written authorization;
- modifications are made to our material without prior written authorization;
- the parts or lubricants used are not original INOXPA parts/lubricants;
- the material has been improperly used due to error or negligence or have not been used according to the indications and the intended purpose.

The General Delivery Terms which you have already received are also applicable.

#### **INOXPA SERVICE.**

In the event of doubt or should you require a fuller explanation on particular data (adjustment, assembly, disassembly...), please do not hesitate to contact us.

## 2. Table of Contents

<b>1. Introduction</b>	
Check the shipment .....	1.1
Instructions manual .....	1.1
Start-up instructions .....	1.1
Maintenance .....	1.1
Operating principles .....	1.1
Warranty .....	1.3
INOXPA Service .....	1.3
<b>2. Table of Contents</b>	
<b>3. General Information</b>	
Description .....	3.1
Principle of operation .....	3.1
Noise .....	3.1
Application .....	3.1
Hygiene .....	3.1
Materials used in construction .....	3.1
Fields of application .....	3.2
Shaft sealing .....	3.3
<b>4. Installation</b>	
General considerations .....	4.1
Instructions upon delivery, for transport and storage .....	4.1
Weights .....	4.1
Location .....	4.2
Stability .....	4.2
Handling .....	4.2
Electric motors .....	4.2
Direction of rotation .....	4.3
Suction an discharge pipes .....	4.4
<b>5. Start-up</b>	
General considerations .....	5.1
Cleaning .....	5.1
Start-up .....	5.1
<b>6. Maintenance</b>	
General considerations .....	6.1
Preparations .....	6.1
Conservation .....	6.1
External cleaning .....	6.1
Electrical installation .....	6.1
Maintenance .....	6.2
<b>7. Operating Problems</b>	
<b>8. Disassembly and Assembly</b>	
General considerations .....	8.1
Disassembly and assembly. Impulsion coer .....	8.2
Impeller .....	8.2
Mechanical seal .....	8.2
Motor replacement .....	8.3

## **9. Technical Specifications**

Technical specifications .....	9.1
Materials .....	9.1
ASPIR MR pump dimensions .....	9.2
ASPIR MB pump dimensions.....	9.3
ASPIR pump motor coupling dimensions .....	9.4
ASPIR pump with flameproof motor dimensions .....	9.5
ASPIR MR pump .....	9.6
Parts list ASPIR MR pump .....	9.7

## **10. Cleaning and Disinfection**

General considerations .....	10.1
Hygiene .....	10.1
Safety in cleaning and disinfection .....	10.2

## 3. General Information

### DESCRIPTION.

The self-priming pumps in the ASPIR series are manufactured using AISI 316 stainless steel die-pressed steel plate and steel casting with an electro-polished finish.

The ASPIR pump has a compact construction, monoblock, vertical intake and discharge, and sanitary-type connections. The impeller is of open design and made of one single piece. The mechanical seal is balanced, outside assembly and fully sanitary. The friction surfaces are silicon carbide, graphite and EPDM o-rings in the standard version.

The motor conforms to the IEC standard with a stainless steel facing, IP-55 protection. Class-F insulation. Three-phased power supply with 220-240 / 380-420 / 660 V at 50Hz, depending on the power source. The motors can be ordered for working in explosion hazardous environments. Depending on environmental conditions, the motors can be explosion-proof (EExd) or of enhanced safety (EExe).

This equipment is suitable for his use in food process.

### PRINCIPLE OF OPERATION.

The impeller, situated between the intake and discharge difusor, turns as a unique piece with the pump shaft and consists of a given number of blades, depending on the pump model.

With this arrangement, the blades transmit energy to the fluid in the form of kinetic and pressure energy, that is driven through the venturi fox to the discharge pipeline. The pump is not reversible by simple inversion of the direction of rotation. The direction of rotation is clockwise when the pump is seen from the rear part of the motor.

### NOISE.

Particularly when the type of use to which the pump is put determines the level of noise to which the operator is exposed as a result of its handling and installation --if it is similar or greater than 85 dBA-- measures as prescribed in regulation no. 277 dated 15/8/91 should be adopted in order to protect users from the risks which this entails.



**When the noise level in the operating area exceeds 85 dB(A), use special protection.**

### APPLICATION.

As a general rule, the standard version of the ASPIR pumps are used to transfer liquids for the food, chemical and pharmaceutical industries, to decant clean liquids of easy vaporization.

Among the main decanted products, the following stand out:

- wines, musts, alcohols, acetones,...
- solvents, boiling liquids, spirits,...
- colonies, syrups, liquors, oils,...

The hydraulic performance at 50 / 60 Hz is given for each of the pump types. The curves also show the power required and the NPSH required.

### HYGIENE.

Special attention has been given to hygiene and cleaning requirements in the construction of the pump. The number of grooves and dead spaces have been limited to an absolute minimum.

The pump can be cleaned easily and thoroughly by easy disassembly of the pump housing, the impeller and the mechanical seal.

Refer to chapter 10 (Cleaning and disinfection) on how to properly clean the pump and the methods and products to be used.

### MATERIALS USED IN CONSTRUCTION.

All pump parts which are in contact with the product are stainless steel, or are made of tasteless and odorless materials. This makes the pump resistant to corrosion and avoids contamination of the liquid being pumped.



**It is necessary to check and verify that the materials in contact with the product are made for pumping a product which is specifically for human consumption..**

**Table 3.1:** Parts in contact with the liquid.

Part	Material
Aspiration casing	CF-8M (1.4408)
Impulsion cover	AISI 316 (1.4401)
Impeller	CF-8M (1.4408)
Shaft	AISI 316 (1.4401)
Venturi fox	CF-8M (1.4408)

**Table 3.2:** Parts that can be in contact with the liquid.

Part	Material
Lantern	CF - 8 (1.4308)
Clamping ring	AISI 304 (1.4301)

**FIELD OF APPLICATION.**

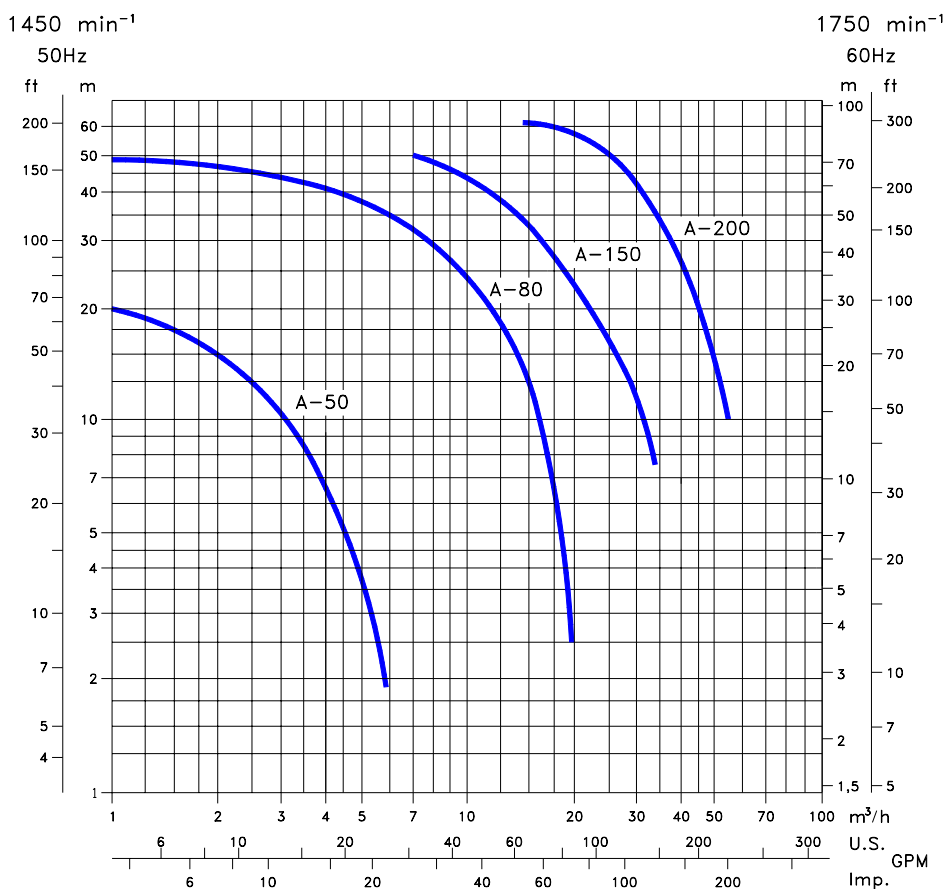

**Figure 3.1:** Field of application.



The field of application for each type of pump is limited. The pump was selected for certain pumping conditions at the time that the order was passed. INOXPA assumes no responsibility for damages that may arise in the event that the information made available by the purchaser is incomplete (nature of the liquid, viscosity, r.p.m. ...).

Do not use the pump for applications other than those for which it has been specified on purchase and installation. No modifications can be made without previously consulting with INOXPA and without the latter's written consent. A correct application shall take into account the following: the viscosity of the product, its properties, purity, temperature, suction and discharge pressure, r.p.m. ...

When the pump is used in a pumping unit or in an environment for which the pump has not been designed, the operator and the material may be exposed to hazard. Consult with INOXPA in case of doubt prior to use.

Refer to Table 3.3 and the corresponding notes for value limits (viscosity, temperature, pressure...).

**Table 3.3:** field of application

	ASPIR	
	50 Hz	60 Hz
Maximum flow rate	56 m <sup>3</sup> /h	50 m <sup>3</sup> /h
Maximum differential pressure	6 bars	5,5 bars
Maximum suction pressure	4 bars	4 bars
Maximum temperature	120 °C	120 °C
Maximum recommended viscosity	250 mPa.s.	250 mPa.s.
Maximum speed	1450 min <sup>-1</sup>	1750 min <sup>-1</sup>
Maximum suction	7 m.	7 m.

### SHAFT SEALING.

The following options for the mechanical seal are applicable to the entire range of pumps.

- Outside mechanical seal.

**Table 3.4:** Materials for faces exposed to friction and internal mechanical seal elastomers

	Rotating part	Stationary part	Elastomers
standard	silicon carbide	graphite	EPDM
option	silicon carbide	silicon carbide	EPDM
	Stainless steel	graphite	Viton

The elastomers of the mechanical seal options can be of PTFE.

# 4. Installation

## GENERAL CONSIDERATIONS.

This manual provides basic instructions which should be taken into account when proceeding to install the pump. It is of utmost importance that the shop foreman read this manual before assembly.

The instructions include pertinent information which will enable you to install your pump correctly. The manual also contains important instructions for preventing possible accidents and serious damage which could occur prior to start up and during the installation :

- It is imperative to put warning markers on the pump, e.g., arrows which indicate the direction of rotation or symbols indicating fluid connections. All these warnings should be clearly visible and legible.
- Any failure to comply with the instructions could result in a risk for the operators, the surroundings and the machine, and could result in the loss of any right to make a claim for damages.

## INSTRUCTIONS UPON DELIVERY, FOR TRANSPORT AND STORAGE.

When the machine arrives, read the instructions on page 1 of the chapter titled "Introduction".



**ASPIR pumps are often too heavy to be stored manually. Use an adequate means of transport. Use the points which are indicated in the drawing for lifting the pump. Only authorized personnel should transport the pump. Do not work or walk under heavy loads.**

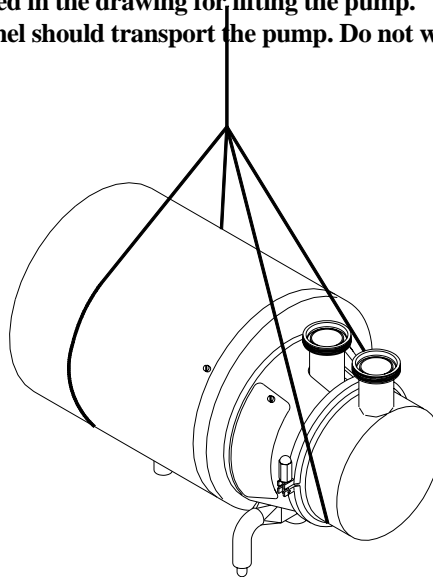

Figure 4.1: Lifting the pump.

## WEIGHTS.

TYPE	Motor acr. IEC 50 Hz [kW]	Pump without motor (kg)		Pump with motor (kg)	
	1450 min <sup>-1</sup>	MR	MB	MR	MB
A-50	0.75	17	14	27	24
A-80	2.2	37	32.5	58	53.5
	3			61	56.5
	4			64	59.5
	5.5			71	66.5
A-150	4	32	27.5	59	54.5
	5.5			66	61.5
A-200	11	79	69	151	141
	15			166	156

**MR** = shrouded pump.

**MB** = unshrouded pump.

## LOCATION.

### Piping.

Place the pump as close as possible to the suction tank (refer to the chapter, "Pump Installation"), and if possible below the level of the liquid or even lower in relation to the deposit so that the static manometric suction head is at its maximum. Place the suction and discharge piping in straight runs with a minimum of elbows and fittings in order to reduce to the extent possible any loss of head caused by friction. This improves the suction conditions, thereby affording maximum performance of the pump.

### Accessibility.

Place the pump so that access can be had to the pump and to the drive units so as to make inspections and revisions. Leave sufficient space around the pump for proper inspection, separation of the pump from other units and for maintenance operations. In order to disassemble the pump you should leave sufficient space in front of and behind it. (Chapter 9 deals with the dimensions).

Place the pump with sufficient space for the lifting equipment if the components or the total weight of the unit exceed 22 kg.

Place the pump near the drain on the floor.

It is very important to be able to gain access to the pump connecting device (including when it is operating).

### Outdoor installation.

The ASPIR pump can only be installed out of doors if there is a roof covering or the pump is shrouded. Consult with INOXPA prior to installation.

### Indoor installation.

Place the pump so that the motor is properly ventilated. Prepare the motor to be started according to the instructions provided by the manufacturer.



**When inflammable or explosive liquids are pumped, an adequate connection needs to be used. Connect the components of the unit with grounding jumpers in order to reduce the danger from static electricity.**

Use explosion-proof motors in accordance with national and local standards and regulations.

### Excessive temperatures.

Depending on the fluid to be pumped, high temperatures can be reached inside and around the pump.



**Over 70 °C the operator should take protective measures and place warning notices advising of the danger which exists if the pump is touched. The type of protection selected should not isolate the pump entirely. It should allow for optimum cooling of the motor.**

## STABILITY.

### Foundation.

Prepare the foundation so that the pump is level and well supported. Its emplacement should be rigid, horizontal, flat and resistant to vibrations, so as to avoid any warping (if the pump's alignment is maintained its operation is ensured during start-up).

## HANDLING.



**If the pump is supplied without a motor, the purchaser/user is responsible for the pump's start-up and assembly.**

## ELECTRIC MOTORS.

### Regulations.

Prior to connecting an electric motor to the power supply, check local regulations on electrical safety and also refer to the EN 60204-1 standard.



**Let qualified personnel perform the connection of electrical motors. Take the necessary steps to prevent faults in the connections and wiring.**

### Automatic switch.

In order to work on the pump without hazards, an automatic switch should be installed as close as possible to the pump. The use of a grounding switch is also recommended.



**The equipment used for handling the pump should comply with current regulations, as set forth in the EN 60204-1 standard on electrical safety.**

### Protection of the motor against overloads.

In order to protect the motor from overloads and short circuits, the use of thermal or magnetic relays is recommended. Adjust these relays to maximum rated current values as indicated on the data plate of the motor.

### Connection.

Consult the supplier's instructions prior to connecting the motor to the power net.

For single-phase motors, use motors with an increased starting torque.

Ensure a starting torque which is sufficiently high for motors controlled by a frequency changer, and which provide for adequate cooling at low speeds. If necessary, install an independent fan.



**The electrical equipment, the terminals and the control system components can continue to carry current when disconnected. Any contact with them can endanger the safety of the operators or cause irreparable damage to the material.**

### DIRECTION OF ROTATION.

The direction of rotation is clockwise viewing the pump from the rear part of the motor.



**Make sure that the pump rotates in the direction indicated on the plate. If the pump rotates in the wrong direction its hydraulic performance will be lower.**

### Electrical diagram.

	Connection U=...	
	3x220	3x380
motor		
220/380	$\Delta$	$\text{Y}$
380	-	$\Delta$

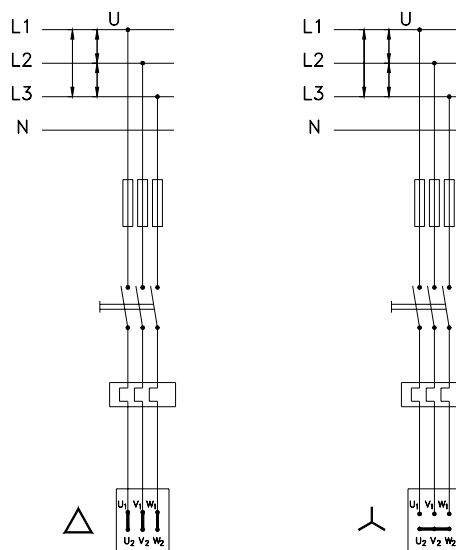

**Figure 4.2:** Electrical Connections

### SUCTION AND DISCHARGE PIPES.

Excessive forces and tensions on pump connections, caused by the piping, could result in mechanical damage to the pump.

These pipes should be connected in a straight line, without leaving spaces between connections and the faces of parallel connections.

Provide for adequate anchoring devices and make sure that they are not tensed too much when the pump is operating.

When hot liquids are pumped, pay attention to thermal expansion; if this is the case, use expansion joints.

Once the connection has been made, check that the shaft can turn freely.

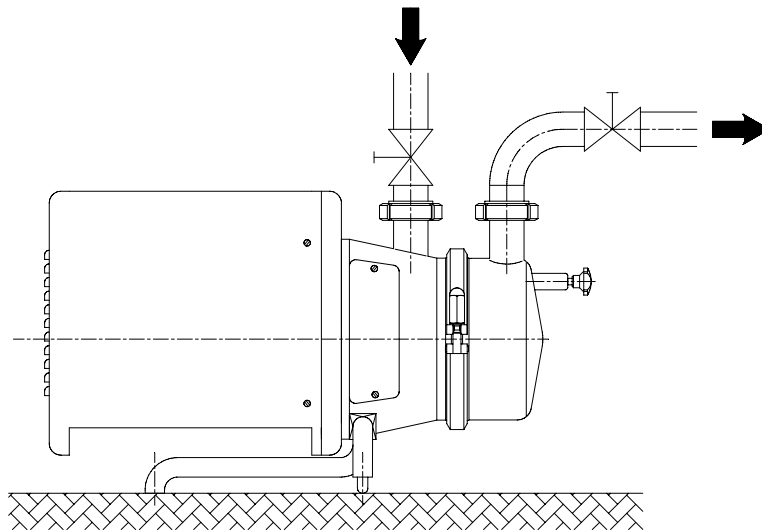

**Figure 4.3:** Suction and discharge pipe

**Pipes.**  
Use pipes with a diameter which is equal to or greater than that of the pump's connections. If the liquid to be pumped is viscous, the loss of head from the suction and discharge pipes can increase considerably. Other pipe components such as valves, elbows, filters and foot valves, can also cause a loss of head.  
For this reason, the diameters and the length of pipes and other components should be selected so that the pump will operate within the minimum pressure limits allowed for the suction (refer to NPSH graph), the maximum working pressure (refer to chapter 3, "Field of Application"), and the rated motor power.

**Suction pipe.**

Liquids should be introduced into the pump from a higher level than that of the pump; the pipe should be inclined in its path to the pump and devoid of air pockets.



**A diameter which is too small or a suction pipe which is too long, a filter too small or clogged, will lead to a greater loss of head and thus the NPSH available (NPSHa) is less than the required NPSH (NPSHr). Cavitation may occur, causing noise and vibrations. The possibility that the pump may also suffer mechanical**

If a filter is installed in the suction mouth, a constant check for loss of load in the suction pipe should be made. Also check to see whether the suction pressure at the suction mouth of the pump is sufficiently high (see NPSH).  
Check the tension of the suction pipe after its connection.

**Priming process.**

In general terms --if the self-priming process is followed-- it is necessary for the pump to contain sufficient liquid to fill the housing, enabling the pump to create a pressure difference.

In order to eliminate air and gases from suction pipe, the counter-pressure on the discharge pipe should be reduced. When the priming process is used, the pump's start-up should be done by opening and emptying the discharge pipe which allows the air and gases to escape at a low counter-pressure.

Another possibility involves long pipes or when a check valve is installed in the discharge pipe; it is also possible to install a by-pass with a shut-off valve on the discharge side of the pump. This valve will open in the case of priming and will allow air and gases to escape at a minimum counter-pressure.

The by-pass should not lead back to the suction mouth but rather it should lead to the supply tank.

**Shut-off valves.**

The pump should be isolated for proper maintenance. This isolation can be obtained by installing shut-off valves in the suction and discharge pipes of the pump.

These valves should be able to open completely, both for suction and for discharge, as occurs with the suction and discharge pipes (ball-checks or sluice valves are preferable).



**When the pump is started up, the shut-off valves should be completely open. The flow rate should never be regulated by closing the shut-off valve in the suction or discharge pipe.**

The flow rate is to be regulated using a by-pass incorporated to impulsion cover or an outside by-pass that re-directs the flow to the supply tank. The operation of the by-pass corporate consists of opening or closing manually the valve in order to let go by more or less fluid by the discharge mouth.

**Filters.**

Foreign particles can seriously damage the pump. Avoid the entry of these particles by installing a filter.

When selecting a filter, bear in mind the diameter of the screen openings so that loss of head will be minimal. The filter diameter should be three times greater than that of the suction pipe.

The filter should be placed in such a way that it does not interfere with maintenance and cleaning operations. Be sure that the density of the liquids is appropriate and that they can be filtered easily.

## 5. Start-up

### GENERAL CONSIDERATIONS.

The pump can be started up so long as the instructions given in chapter 4 ("Installation") have been followed.



**Prior to start-up, the persons responsible for the operation must be duly informed of the pump's operation and the safety instructions. This instruction manual should be available to personnel at all times.**  
**Prior to start-up, check the pump for any possible failure. If a failure is found, the plant foreman should be notified immediately.**

Also consult the section "Dimensions" in chapter 9.

### CLEANING.



**Prior to start-up, check to see that the pipes and the pump are completely clean and devoid of weld splatterings or other foreign particles.**

Consult chapter 10 (cleaning and disinfection) on how to properly clean the pump and the methods and liquids which should be used.

### START-UP.

- Completely open the shut-off valves in the suction and discharge pipes.
- If the liquid does not flow into the pump, fill it with liquid when pumping.



**The pump should never rotate when empty.**



**When the pump draw in from an inferior level at level of the pump, prime the pump.**

- If the pump has the flow by-pass option, when this draw in from an inferior level of the pump, the by-pass will have to be closed why it will not draw in.
- Check to see if the pump can be started up safely.
- Start the pump.
- Check to see whether the absolute suction pressure is sufficient, so that vapour cannot be produced inside the pump. Refer to the curve for the minimum pressure required above the vapour pressure (NPSH).
- Control the discharge pressure.



**A shut-off valve should not be used in the suction pipe to regulate the flow rate. It must be completely open during operation.**

# 6. Maintenance

## GENERAL CONSIDERATIONS.



Inadequate, wrong or improper maintenance could result in the faulty operation of the pump, high repair costs, and breakdown in the long run. For this reason the instructions given in this chapter should be followed.

During maintenance operations which are performed on the pump, whether due to inspections, preventive maintenance or the movement of the installation, the procedures indicated should always be followed.

Failure to comply with these instructions could endanger the operator and/or seriously damage the pump. Maintenance work should only be done by qualified personnel. Wear appropriate clothing which provides adequate protection against high temperatures and hazardous and/or corrosive fluids. Make sure that the personnel read the entire instruction manual and, in particular, indicate to them the chapters which refer to work which needs to be done.

INOXPA does not assume responsibility for accidents and damage which might occur as a result of any failure to comply with the instructions indicated herein.

## PREPARATION.

### Work area.

Provide for a clean work area; some parts are extremely delicate and others support small tolerances.

### Tools.

Use tools which are designed for the purpose for which they are to be used in maintenance and repair work. Use them properly.

### Disconnection.

Before beginning maintenance and inspection work, disconnect the pump.

Decompress the pump and the pumping unit.

If the fluid to be pumped allows for it, let the pump cool down until it reaches room temperature.

### Safety.

Do not let the motor start if work needs to be done on the pump. This is very important when electric motors are involved which are connected from a certain distance.

Follow the procedure outlined below:

- Place the pump switch in the "Off" position.
- Disconnect the pump from the power supply.
- Block the electrical control panel or put a warning notice on it.
- Remove the fuses and take them with you to the work area.
- Do not remove the protection pieces located around the lantern until the pump is completely stopped.

## CONSERVATION.

Should the pump be taken out of service for a long period of time:

- First of all, empty the pump.
- Apply VG46 mineral oil to the internal parts.
- The pump should be worked on for a brief period of time once a week or the shaft rotated manually. This ensures the correct circulation of the protective oil.

## EXTERNAL CLEANING.

Attempt to keep the exterior of the pump clean at all times. This helps in inspection work and keeps warning notices visible.

Make sure that cleaning products do not get into the motor's ball bearings. Cover all parts which should not enter into contact with the cleaning fluid.



Do not spray hot parts of the pump with water as some components could crack due to quick cooling and the fluid inside the pump could spill out.

## ELECTRICAL INSTALLATION.

Maintenance work on electrical installations can only be done by qualified personnel and only when the power supply has been cut off. Carefully follow national safety regulations.



**Also abide by the regulations referred to above if you are working while the power supply is still connected.**

Also abide by the regulations referred to above if you are working while the power supply is still connected.



**Check to see whether the electrical materials to be cleaned are well protected (for ex., IP 54 indicates protection against dust and water spray but does not include protection against pressure water jets). Consult EN 60529. Choose an appropriate method of cleaning electrical materials.**

Replace defective fuses with new ones having the prescribed amperage.

On finishing each maintenance operation, check the electrical installation components to see if they are defective and repair them if necessary.

#### **MAINTENANCE.**

Periodically check suction and discharge pressures.

Inspect the motor in accordance with the manufacturer's instructions.

In general, a mechanical seal does not require maintenance; however, the seal should never be made to work when empty. Should a leak occur, replace the seal.

## 7. Operating Problems

Problems	Probable Causes
Overloading of motor.	7, 8, 12
Insufficient flow rate or pressure in pump.	1, 2, 4, 5, 6, 7, 8
No pressure on the discharge side.	2, 3, 6, 16
Irregular discharge flow rate / pressure.	1, 2, 4, 5, 6, 8
Noise and vibrations.	2, 4, 5, 6, 7, 8, 9, 12, 13, 14
The pump gets clogged.	8, 9, 12, 14
Overheating of the pump.	7, 8, 9, 12
Abnormal wear.	4, 5, 7, 9, 12, 14
Leak in mechanical seal.	10, 11, 15

Probable causes		Solutions
1	Wrong direction of rotation.	Invert the direction of rotation.
2	Insufficient NPSH.	Increase available NPSH: - Raise the suction deposit. - Lower the pump. - Reduce the vapour pressure. - Increase the diameter of the suction pipe. - Shorten and simplify the suction pipe.
3	Pump not purged.	Purge or fill.
4	Cavitation.	Increase suction pressure (also see 2)
5	The pump sucks in air.	Check the suction pipe and all its connections.
6	Suction pipe obstructed.	Check suction pipe and the filters, if any.
7	Discharge pressure too high.	If necessary, reduce head losses, for ex., by increasing the pipe diameter.
8	Viscosity of liquid too high.	Reduce the viscosity, for ex., by heating the liquid.
9	Temperature of the liquid too high.	Reduce the temperature by cooling the liquid.
10	Damaged or worn mechanical seal.	Replace the seal
11	O-rings not the right ones for the liquid.	Insert the proper O-rings; check with the supplier.
12	The impeller scrapes.	- Decrease the temperature. - Decrease the suction pressure. - Adjust the clearance between the impeller and the housing.
13	Tension in the pipelines.	Connect the pipelines to the pump free of tension.
14	Foreign objects in the liquid.	Place a filter in the suction. See to chapter 4.
15	Mechanical seal spring tension too low.	Adjust as indicated in the manual.
16	Suction shut-off valve closed.	Check and open.



**If the problems persist stop using the pump immediately. Contact the pump manufacturer or his representative.**

# 8. Disassembly and Assembly

## GENERAL CONSIDERATIONS.

The assembly and disassembly of the pumps should only be done by qualified personnel. Make sure that the personnel read carefully this instruction manual and, in particular, those instructions which refer to the work they will perform.



**Incorrect assembly or disassembly may cause damage in the pump's operation and lead to high repair costs and a long period of down-time.**

**INOXPA is not responsible for accidents or damages caused by a failure to comply with the instructions in this manual.**

### Preparations.

Provide for a clean working environment as some parts, including the mechanical seal, are very delicate and others have little tolerance.

Check that the parts which are used do not suffer damage during transport. When doing this, you need to inspect the adjustment edge, the butted faces, clogging, burrs, etc.

After each disassembly, carefully clean the parts and check for any damage. Replace all damaged parts.

### Tools.

Use the proper tools for assembly and disassembly operations. Use them correctly.

### Tightening torque.

Table 8.1: Tightening torque

Material	Tightening torque N.m.								
	M5	M6	M8	M10	M12	M14	M16	M18	M20
8.8	6	10	25	49	86	135	210	290	410
A4	5	9	21	42	74	112	160	210	300

### Cleaning.

Before disassembling the pump, clean it on the outside and on the inside.



**NEVER clean the pump by hand when it is running.**

### Safety.

Prevent the motor from starting if you need to work on the pump.

Take steps to ensure that the motor cannot be started if the pump housing is removed, for ex., for cleaning operations.



**NEVER cause the pump to run without the housing.**

### Disconnection.



**Before beginning disassembly and assembly work, disconnect the pump. Decompress the pump and the pumping unit.**

If the fluid in the pump allows for it, let the pump cool off until reaching room temperature.

### Electrical safety.

Prevent the motor from starting if you need to work on the pump. This is very important when working with electric motors that are connected from a certain distance.

Follow the procedure outlined below:

- Place the pump switch in the "Off" position.
- Disconnect the pump from the power supply.
- Block the electrical control panel or put a warning notice on it.
- Remove the fuses and take them with you to the work area.
- Do not remove the protection pieces located around the lantern until the pump is completely stopped.

## DISASSEMBLY AND ASSEMBLY.

## IMPULSION COVER.

- Close the suction and discharge valve.



**ATTENTION! The liquid can spill out when the impulsion cover and the venturi fox is removed.**

- Remove the clamp (15).
- Check to see that the O-ring (80A) is still in good condition.
- Make sure that the O-ring is not inverted when inserted.
- Once the impulsion cover (01A) is assembled the clamp needs to be inserted and the wing nut tightened.

## IMPELLER.

*Remove the impulsion cover as indicated in the foregoing section.*

- Remove the venturi fox (16). Can occur that upon the impulsion cover (01A), the venturi fox leave jointly with this.
- Remove the impeller (02). If it would be necessary to use an extracting through th threaded drills of the impeller (02).
- For the assembly of the impeller (02), slide it by the shaft (05) procuring that the key (61) be mounted.

## MECHANICAL SEAL.

### Disassembly of the mechanical seal.

*Previously to follow the commented steps previously.*

- Remove the screws (50A) and retract the protections (47A).
- Remove the screws (52B) and retract the aspiration casing (01).
- The stationary part of the mechanical seal (08) remain put on the aspiration casing (01).
- The rotating part of the mechanical seal remains free in the shaft (05). Remove sliding it by the shaft.
- Prove that the obturation surfaces and the o-ring of the mechanical seal (08) do not are damaged.

### Assembly of the mechanical seal.

- One must to put previously the stationary part of the mechanical seal (08A) on the housing of the aspiration casing (01).
- Slide the rotating part of the mechanical seal (08) on the shaft (05).
- Mount the aspiration casing (01), fixing it with the screws (52B) and the spring flats (53A).
- Prove that the assembly measure A is in agreement with table 8.2. If the measure would not be correct, loose the pins (55) and locate the shaft to the measure A and to tight the pins (55).

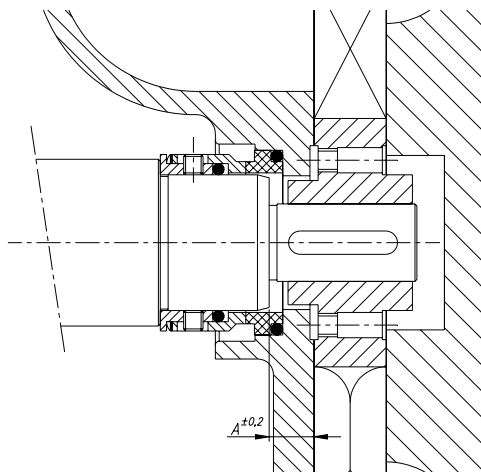

**Figure 8.2 :** mechanical seal

**Table 8.2 :** mechanical seal assembly position

Mechanical seal diameter	A <sup>±0,2</sup> [mm]
A - 50	8
A - 80	11.5
A - 150	8
A - 200	10

**WARNING! When fitting the new seals, be sure to wet the O-rings with soapy water so that the fixed parts slide easily into their locations and the rotating parts onto the shaft.**

## MOTOR REPLACEMENT.

---

*In order to replace the motor (93), follow the indications as given in the foregoing sections disassemblies.*

- Remove the splash ring (82).
- Loosen the studs (55) and take the shaft (05) out.
- Remove the screws (50) and take out the shroud (14); only on the MR version.
- Remove the screws (52) and take the lantern (04) out.

**Replace the motor or its ball bearings as indicated in the manufacturer's instruction manual.**

# 9. Technical Specifications.

## TECHNICAL SPECIFICATIONS.

TYPE	Motor acr. IEC 50 Hz [kW]		shaft sealing	impeller diameter
	1450 min <sup>-1</sup>	Frame	seal diameter	
A-50	0.75	80	28	110
A-80	2.2	100	35	136
	3			
	4	112		
	5.5			
A-150	4	112	35	160
	5.5			
A-200	11	160	35	197
	15			

## MATERIALS.

Parts in contact with the liquid

Part	Item	Material	Material n.
Aspiration casing	01	CF - 8M	(1.4408)
Impulsion cover	01A	AISI 316	(1.4401)
Impeller	02	CF - 8M	(1.4408)
Shaft	05	AISI 316	(1.4401)
Venturi fox	16	CF - 8M	(1.4408)

Parts which can be in contact with the liquid.

Part	Item	Material	Material n.
Lantern	04	CF - 8	1.4308
Clamping ring	15	AISI 304	1.4301

Parts which cannot be in contact with the liquid

Part	Item	Material	Material n.
Legs	07	AISI 304	1.4301
Shroud	14	AISI 304	1.4301

**ASPIR MR pump dimensions.**

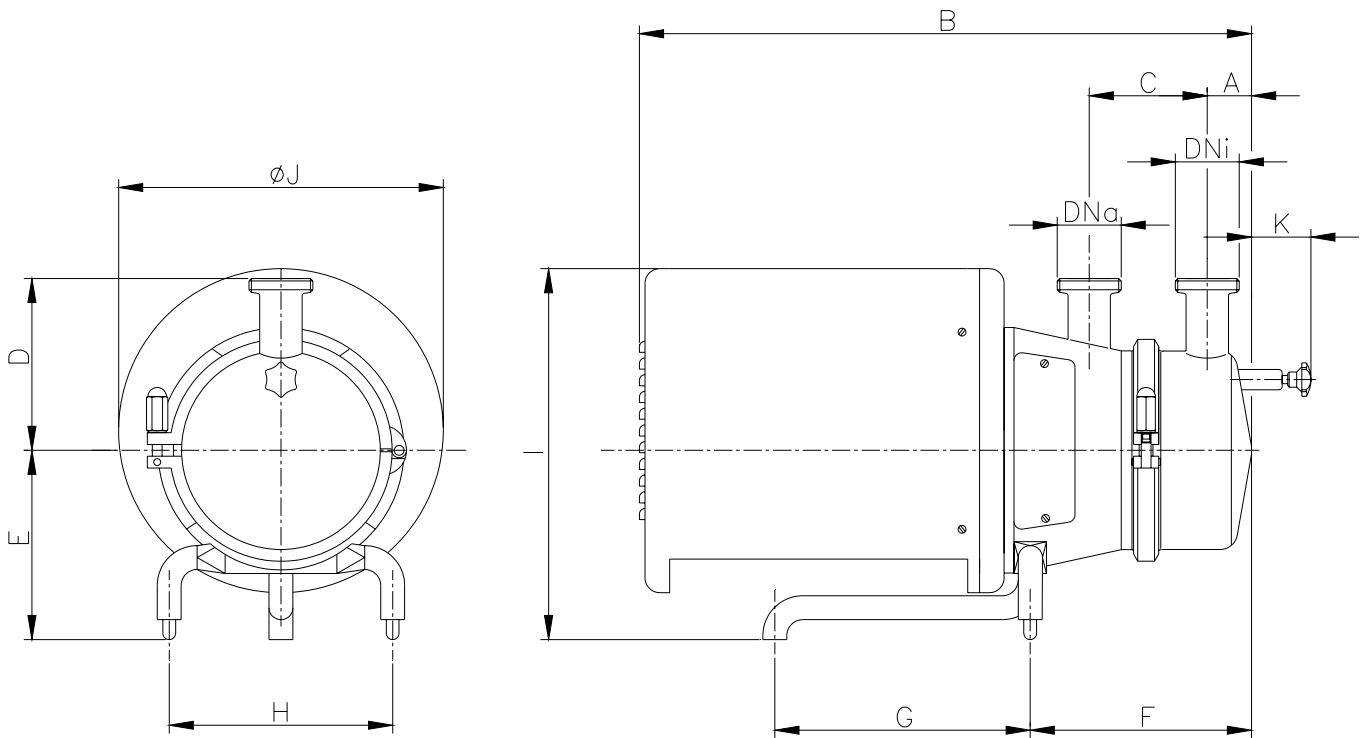

TYPE	Motor kW.	DNa	DNi	A	B	C	D	E	F	G	H	I	ØJ	K
A-50	0.75	32 1½"	32 1½"	37	490	86	125	165	158	235	205	325	270	57
A-80	2.2	40 1½"	40 1½"	45	625	120	175	190	225	275	205	375	330	65
	3													
	4													
A-150	4	50 2"	50 2"	45	625	120	175	190	225	275	205	375	330	62
	5.5													
A-200	11	65 3"	65 3"	60	947	150	225	280	313	355	320	555	465	59
	15													

Dimensions with connections DIN 11851

**ASPIR MB pump dimensions.**

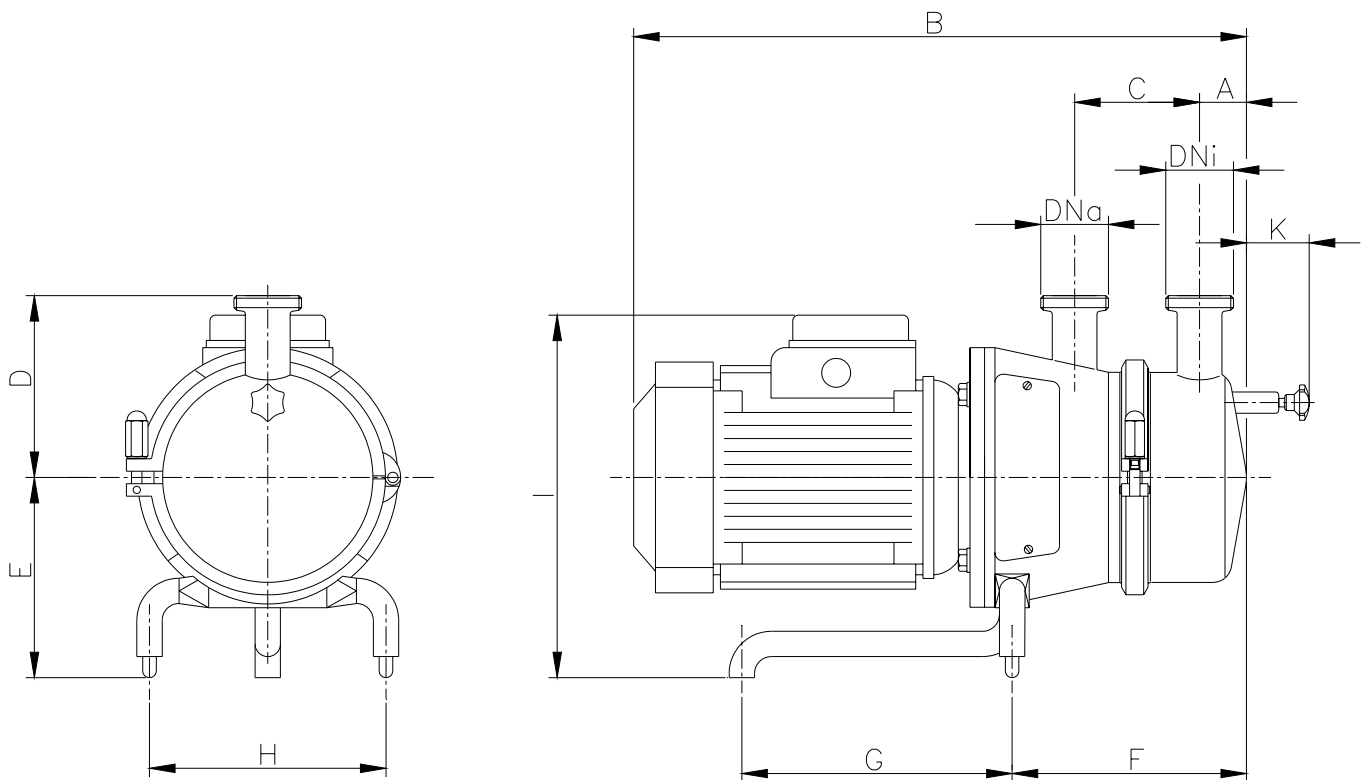

TYPE	Motor kW.	DNa	DNi	A	B	C	D	E	F	G	H	I	K
A-50	0.75	32 1½"	32 1½"	37	420	86	125	165	158	235	205	275	57
A-80	2.2	40 1½"	40 1½"	45	550	120	175	190	225	275	205	326	65
	3				555							336	
	4												
	5.5												
A-150	4	50 2"	50 2"	45	555	120	175	190	225	275	205	336	62
	5.5												
A-200	11	65 3"	65 3"	60	825	150	225	280	313	355	320	524	59
	15				870								

Dimensions with connections DIN 11851

**ASPIR pump motor coupling dimensions.**

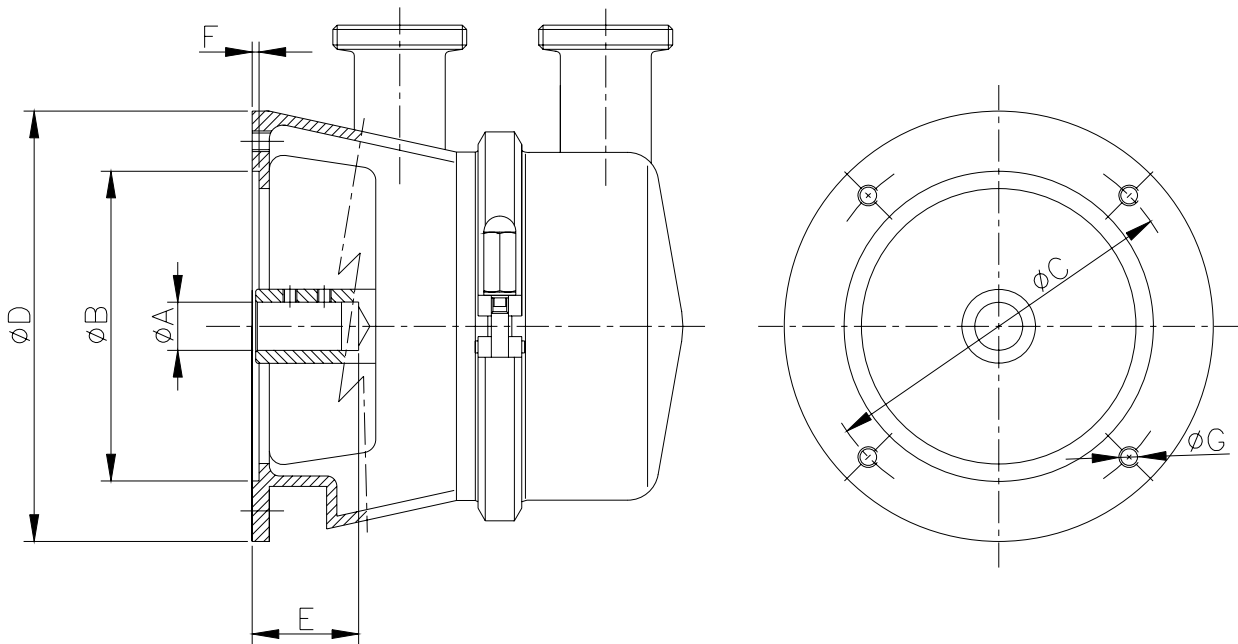

TYPE	Motor frame	A	B	C	D	E	F	G
A-50	80	19	130	165	200	42	3,5	M10
A-80	100/112	28	180	215	250	62	4	M12
A-150	100/112	28	180	215	250	62	4	M12
A-200	160	42	250	300	350	112	5	M16

**ASPIR pump with flameproof motor dimensions.**

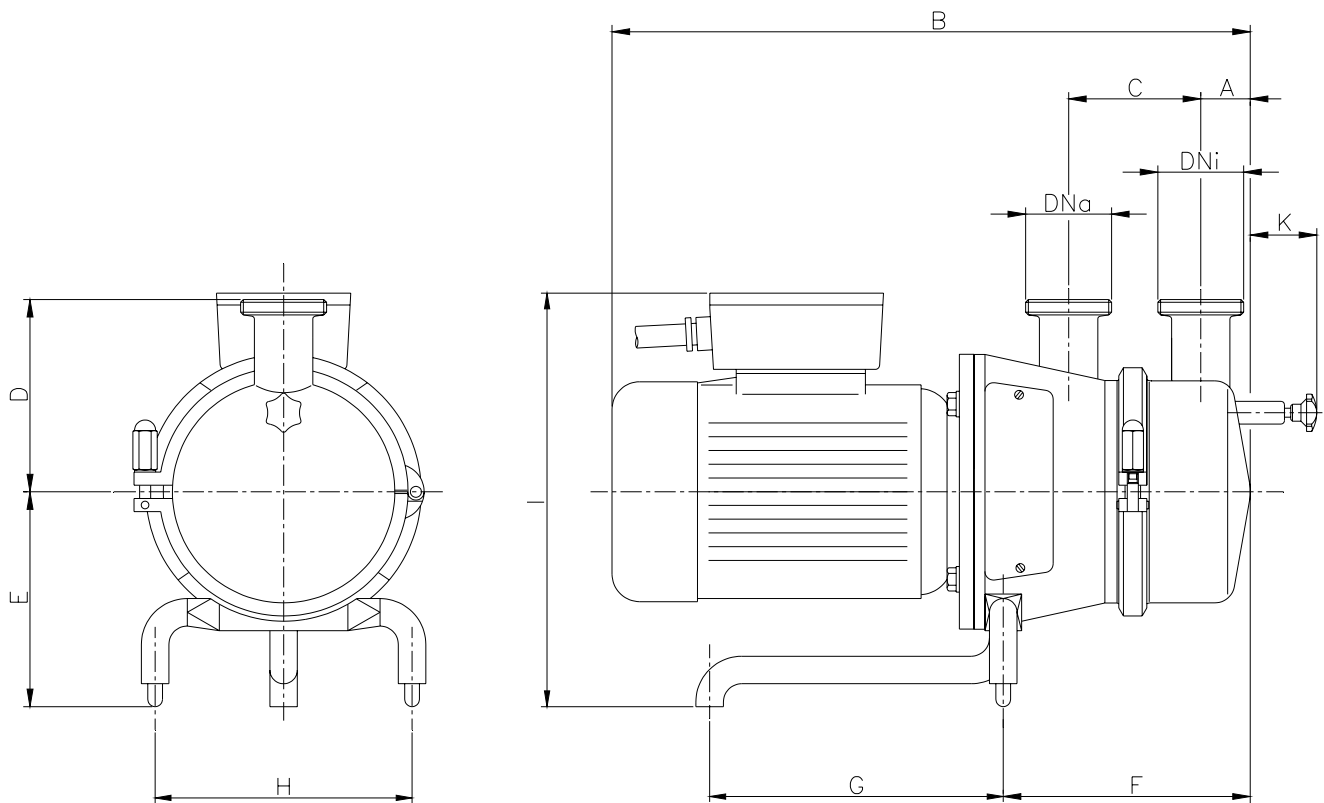

TYPE	Motor kW.	DNa	DNi	A	B	C	D	E	F	G	H	I	K
A-50	80	32 1½"	32 1½"	37	470	86	125	165	158	235	205	320	57
A-80	100	40 1½"	40 1½"	45	630	120	175	190	225	275	205	355	65
	112				665							410	
A-150	112	50 2"	50 2"	45	665	120	175	190	225	275	205	410	62
A-200	160	65 3"	65 3"	60	925	150	225	280	313	355	320	535	59

Dimensions according to flameproof motor CEMP.

ASPIR MR pump.

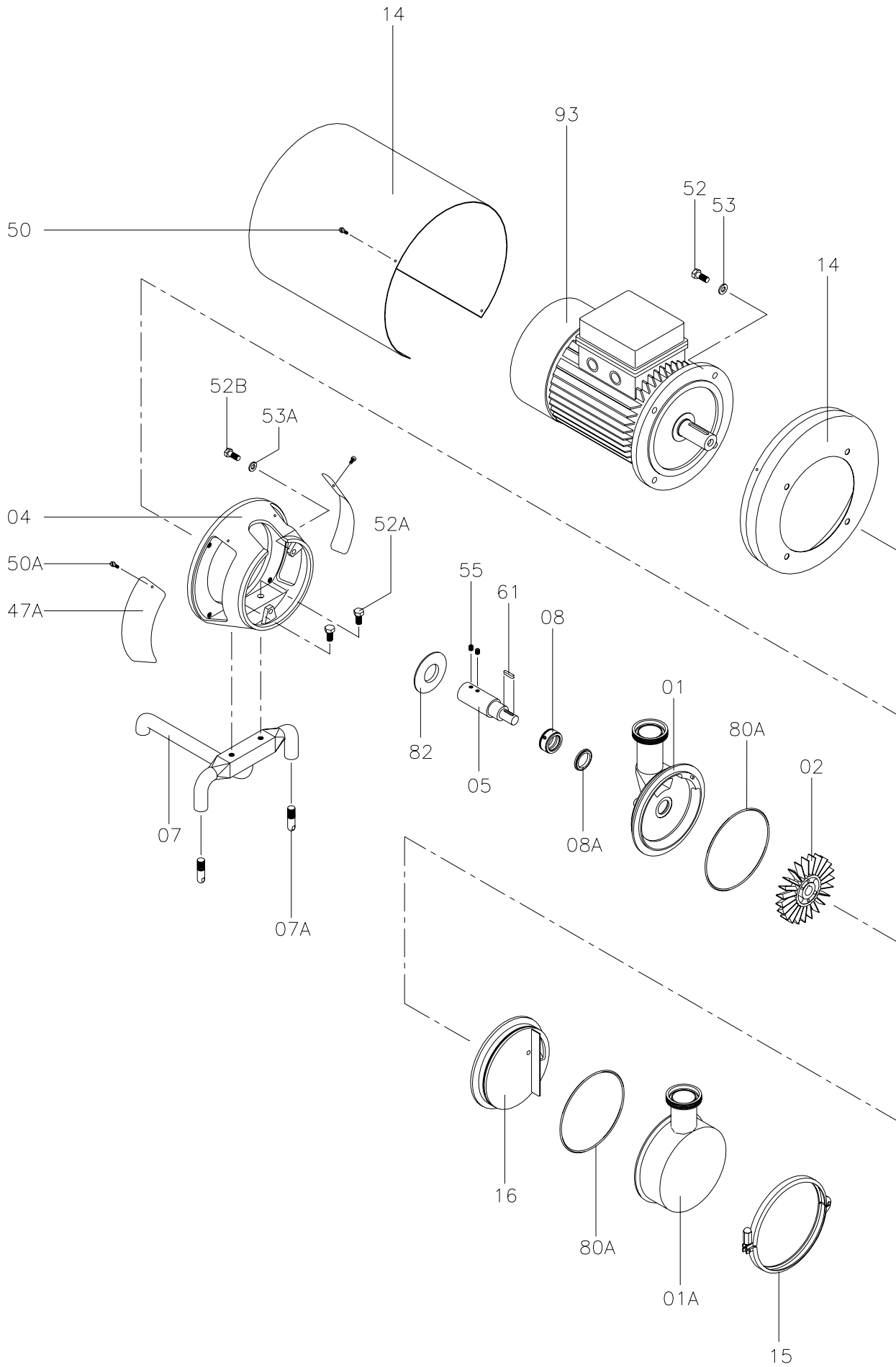

**Parts list ASPIR MR.**

<b>Position</b>	<b>Quantity</b>	<b>Description</b>	<b>Material</b>
01	1	Aspiration casing	CF - 8M
01A	1	Impulsion cover	AISI 316
02	1	Impeller	CF - 8M
04	1	Lantern	CF - 8
05	1	Shaft	AISI 316
07	1	Legs	AISI 304
07A	2	Adjustable leg	AISI 304
08	1	Mechanical seal –rotating part-	-
08A	1	Mechanical seal –stationary part-	-
14	1	Shroud	AISI 304
15	1	Clamping ring	AISI 304
16	1	Venturi fox	CF - 8M
47A	2	Protection	Plastic
50	4	Screw	A2
50A	4	Screw	A2
52	4	Hexagonal screw	A2
52A	2	Hexagonal screw	A2
52B	3	Hexagonal screw	A2
53	4	Flat washer	A2
53A	3	Spring flat	A2
55	2	Pin	A2
61	1	Key	AISI 304
80A	2	O-ring	EPDM
82	1	Splash ring	EPDM
93	1	Motor	-

# 10. Cleaning and Disinfection

## GENERAL CONSIDERATIONS.

Cleaning and disinfection of the installations is necessary and mandatory on completing any manufacturing process in the food industry. The use of an installation which is NOT cleaned or disinfected can cause contamination of the products. The cleaning cycles as well as the chemical products and procedures used will vary depending on the product and the manufacturing process.

It is the user's responsibility to establish an appropriate cleaning or disinfection program according to his needs. Such a program needs to take into account all applicable laws, regulations and standards pertinent to public health protection and safety in the use of chemical products.

## HYGIENE.

Special attention has been given to hygiene and cleaning and disinfection operations in the design of the ASPIR pump. The number of grooves and dead spaces have been kept to a minimum. The materials used in making the pump have been selected for their resistance to corrosion and so as not to contaminate the liquid to be pumped.

### Cleaning.

The pump can be cleaned easily and thoroughly in one of two ways:

- without disassembling it, for ex., using steam or water, referred to as CIP ("Cleaning in Place).
- by simply disassembling the pump housing, the impeller and the mechanical seal (see Assembly and Disassembly).

It is important that the pump be running during the CIP process in order to obtain the most thorough cleaning. During the automated CIP processes the pump could be started up unexpectedly because of some remote signal. This could cause serious damage to anyone who is in contact with the pump.



**NEVER disassembly the pump during the CIP cleaning process. Disconnect the electrical supply to the pump and take those steps which are needed for safety before beginning any manual cleaning operation on the pump.**

Direct contact with cleaning or disinfecting solutions can provoke burns due to chemical agents or high temperatures.



**Provide personnel responsible for cleaning operations with adequate protective equipment --clothing, footwear, safety glasses-- in order to avoid any hazard.**

Train personnel in the safe use and handling of chemical solutions and high working temperatures.

### Disinfection.

Disinfection cycles are used to kill bacteria on the surfaces in contact with the product before the manufacturing process takes place. Disinfecting solutions are extremely corrosive, especially those which contain halogen components (chloride, bromide, iodine) or strong acids (nitric, hydrochloric).

When metal parts are allowed to remain in contact for a longer period of time with the solutions containing chemical agents, even these attack the stainless steel parts of a pump. To avoid serious damage:

- Do NOT disinfect the pump earlier than 15 minutes before beginning production.
- Do NOT leave disinfecting solutions in prolonged contact with pump surfaces or the outside of it. Drops of dried solution are more concentrated and can provoke corrosion points or pitting.
- Do NOT use strong concentrations, high temperatures or exposure times over and above those required to obtain an effective disinfection.

## SAFETY IN CLEANING AND DISINFECTION.



### Manual cleaning.

- **Disconnect the motor starting system before cleaning the pump.**
- **Provide cleaning personnel with the most appropriate protective equipment -clothing, footwear, safety glasses.**
- **Do not use toxic or inflammable solvents for cleaning the pump.**
- **Clean up any water spilled around the pump as soon as possible.**
- **With the pump running, NEVER clean it by hand.**



### CIP Procedure.

- **Make sure that all cleaning circuit connections are securely tightened so as to avoid splashing of hot water or cleaning solutions.**
- **Establish a safety device in the event of any failure in the automatic process and avoid automatic start-up.**
- **Check to see that the aspiration casing and impulsion cover are well-positioned and securely tightened.**
- **Do not disassemble any pipes, fittings or the pump without being sure that the cleaning cycle is completely finished.**

For reference purposes for the user, the cleaning methods and products used can be those mentioned in the DIN 11483 standard