



**JOHNSON PUMP**  
AN SPX BRAND

# Instruction Manual

## CombiPrime V

### Vertical self-priming centrifugal pump



Read and understand this manual prior to operating or servicing this product.

CV/EN (0808) 5.1

**SPX**<sup>®</sup>

## EC Declaration of conformity

(Directive 98/37/EC, appendix II-A)

### Manufacturer

SPX Process Equipment NL B.V.  
Dr. A.F. Philipsweg 51  
P.O. Box 9  
9400 AA Assen  
The Netherlands

hereby declares that the pump, in case it is delivered as an assembly with drive (last position of serial number = A), is in conformity with the provisions of Directive 98/37/EC (as altered most recently) and the following directives and standards:

- EC directive 2006/95/EG, "Electric equipment for use within certain voltage limits"
- standards EN-ISO 12100 part 1 & 2, EN 809

The pump to which this declaration refers may only be put into operation after it has been installed in the way prescribed by the manufacturer, and, as the case may be, after the complete system of which this pump forms part, has been made to fulfil the requirements of Directive 98/37/EC (as altered most recently).

## Manufacturer's declaration

(Directive 98/37/EC, appendix II-B)

### Manufacturer

SPX Process Equipment NL B.V.  
Dr. A.F. Philipsweg 51  
P.O. Box 9  
9400 AA Assen  
The Netherlands

hereby declares that the pump, in case it is delivered without drive (last position of serial number = B), is in conformity with the following standards:

- EN-ISO 12100 parts 1 & 2, EN 809

and that this pump is meant to be incorporated in or combined with another machine (electric motor, combustion engine) and may only be put into use after the complete machine of which the pump under consideration forms part has been made and declared to comply with that directive.

Assen, May 1st 2008

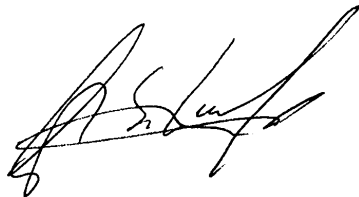

G.A. Schaafsma,  
Managing Director



# **Instruction manual**

# **CombiPrime V**

All technical and technological information in this manual as well as possible drawings made available by us remain our property and shall not be used (otherwise than for the operation of this pump), copied, duplicated, made available to or brought to the notice of third parties without our prior written consent.

SPX Process Equipment NL B.V. (hereafter called Johnson Pump) is part of SPX Process Equipment AB. The core activities of SPX Process Equipment AB are the development, production, sale and maintenance of pumps and pump units.

SPX Process Equipment NL B.V.  
P.O. Box 9  
9400 AA Assen  
The Netherlands  
Tel. +31 (0)592 376767  
Fax. +31 (0)592 376760  
[www.johnson-pump.com](http://www.johnson-pump.com) or [www.spxpe.com](http://www.spxpe.com)

© 2008 SPX Process Equipment NL B.V.



# Table of Contents

<b>1</b>	<b>Introduction</b>	<b>9</b>
1.1	Preface	9
1.2	Safety	9
1.3	Guarantee	10
1.4	Inspection of delivered items	10
1.5	Instructions for transport and storage	11
1.5.1	Dimensions and weight	11
1.5.2	Use of pallets	11
1.5.3	Hoisting	11
1.6	Storage	11
1.7	Ordering parts	11
<b>2</b>	<b>General</b>	<b>13</b>
2.1	Pump description	13
2.2	Type code	13
2.3	Application	14
2.4	Construction	14
2.4.1	Pump casing/impeller/suction bend	14
2.4.2	Shaft sealing	14
2.4.3	Self-priming part	15
2.4.4	Bearing construction	15
2.4.5	Lantern construction	15
2.4.6	Foot pads	15
2.5	Application area	15
2.6	Re-use	16
2.7	Scrapping	16
<b>3</b>	<b>Installation</b>	<b>17</b>
3.1	Safety	17
3.2	Preservation	17
3.3	Environment	17
3.4	Mounting	18
3.4.1	Installation of a pump unit	18
3.4.2	Assembling a pump unit	18
3.4.3	Alignment of the coupling	19
3.5	Piping	20
3.6	Accessories	20
3.7	Vacuum pump with service liquid tank	21
3.7.1	Mounting of accessories	21
3.7.2	Connection diagram with service liquid tank	21

3.7.3	Indication of connections	21
3.7.4	Installation examples with service liquid tank	22
3.8	Vacuum pump with float-controlled de-aerator	26
3.8.1	Mounting of accessories	26
3.8.2	Connection diagram with float-controlled de-aerator	26
3.8.3	Indication of connections	26
3.8.4	Installation examples with float-controlled de-aerator	27
3.9	Connection of the electric motor	30
<b>4</b>	<b>Commissioning</b>	<b>31</b>
4.1	Inspection of the pump	31
4.2	Inspection of the vacuum pump part	31
4.3	Inspection of the motor	31
4.4	Checking the sense of rotation	31
4.5	Start-up	31
4.6	Adjusting the air-inlet valve	32
4.7	Mechanical seal	32
4.8	Pump in operation	32
4.9	Noise	32
<b>5</b>	<b>Maintenance</b>	<b>33</b>
5.1	Daily maintenance	33
5.2	Service liquid	33
5.3	Shaft sealing	33
5.3.1	Mechanical seal	33
5.3.2	Lip seal	33
5.4	Lubrication of the bearings	33
5.5	Environmental influences	34
5.6	Noise	34
5.7	Faults	34
<b>6</b>	<b>Problem solving</b>	<b>35</b>
<b>7</b>	<b>Disassembly and assembly</b>	<b>37</b>
7.1	Precautionary measures	37
7.2	Tools	37
7.3	Liquid draining	37
7.4	Item numbers	37
7.5	Construction variants	38
7.6	Top-Pull-Out system	38
7.6.1	Disassembly Top-Pull-Out unit	38
7.6.2	Assembly Top-Pull-Out unit	38
7.7	Replacement of impeller and wear ring	39
7.7.1	Disassembly of the impeller	39
7.7.2	Assembly of the impeller	39
7.7.3	Disassembly of the wear ring	40
7.7.4	Assembling the wear ring	40
7.8	Shaft sealing	41
7.8.1	Disassembly of the mechanical seals M2	41
7.8.2	Instructions for mounting a mechanical seal	42
7.8.3	Assembly of the mechanical seals M2	42
7.8.4	Disassembly of the lip seals M4	43
7.8.5	Instructions for mounting a lip seal	44
7.8.6	Assembly of the lip seals M4	44
7.9	Bearing	45
7.9.1	Disassembly of bearings and pump shaft	45

7.9.2	Assembly of bearings and pump shaft	46
7.10	Adjustment of the axial play	47
<b>8</b>	<b>Dimensions</b>	<b>49</b>
8.1	Dimensions delivery flange	49
8.2	Dimensions suction flange	50
8.3	Dimensions foot pads	50
8.4	Dimensions pump	51
8.5	Dimensions pump with service liquid tank	53
8.6	Dimensions pump with float de-aerator	55
<b>9</b>	<b>Parts</b>	<b>57</b>
9.1	Ordering parts	57
9.1.1	Order form	57
9.1.2	Recommended spare parts	57
9.2	Pump parts	58
9.3	Parts of shaft sealing group M2	61
9.4	Parts of shaft sealing group M4	62
9.5	Parts of service liquid tank TL	63
9.6	Parts of float de-aerator VL	65
9.7	Parts of suction bend	67
<b>10</b>	<b>Technical data</b>	<b>69</b>
10.1	Recommended greases	69
10.2	Recommended locking liquids	69
10.3	Tightening moments	69
10.3.1	Tightening moments for bolts and nuts	69
10.3.2	Tightening moments for cap nuts	69
10.4	Hydraulic performance	70
10.5	Noise data	72
10.5.1	Pump noise as a function of pump power	72
10.5.2	Noise level of entire pump unit	73
	<b>Index</b>	<b>75</b>
	<b>Order form for spare parts</b>	<b>77</b>



# 1 Introduction

## 1.1 Preface

This manual is intended for technicians and maintenance staff and for those who are in charge of ordering spare parts.

This manual contains important and useful information for the proper operation and maintenance of this pump. It also contains important instructions to prevent potential accidents and damage, and to ensure safe and fault-free operation of this pump.



**Read this manual carefully before commissioning the pump, familiarize yourself with the operation of the pump and strictly obey the instructions!**

The data published here comply with the most recent information at the time of going to press. However they may be subject to later modifications.

Johnson Pump reserves the right to change the construction and design of the products at any time without being obliged to change earlier deliveries accordingly.

## 1.2 Safety

This manual contains instructions for working safely with the pump. Operators and maintenance staff must be familiar with these instructions.

Below is a list of the symbols used for those instructions and their meaning:



**Personal danger for the user. Strict and prompt observance of the corresponding instruction is imperative!**



**Risk of damage or poor operation of the pump. Follow the corresponding instruction to avoid this risk.**



*Useful instruction or tip for the user.*

Items which require extra attention are shown in **bold print**.

This manual has been compiled by Johnson Pump with the utmost care. Nevertheless Johnson Pump cannot guarantee the completeness of this information and therefore assumes no liability for possible deficiencies in this manual. The buyer/user shall at all times be responsible for testing the information and for taking any additional and/or deviating safety measures. Johnson Pump reserves the right to change safety instructions.

### 1.3 Guarantee

Johnson Pump shall not be bound to any guarantee other than the guarantee accepted by Johnson Pump. In particular, Johnson Pump will not assume any liability for explicit and/or implicit guarantees such as but not limited to the marketability and/or suitability of the products supplied.

The guarantee will be cancelled immediately and legally if:

- Service and/or maintenance is not undertaken in strict accordance with the instructions.
- The pump is not installed and operated in accordance with the instructions.
- Necessary repairs are not undertaken by our personnel or are undertaken without our prior written permission.
- Modifications are made to the products supplied without our prior written permission.
- The spare parts used are not original Johnson Pump parts.
- Additives or lubricants used are other than those prescribed.
- The products supplied are not used in accordance with their nature and/or purpose.
- The products supplied have been used amateurishly, carelessly, improperly and/or negligently.
- The products supplied become defective due to external circumstances beyond our control.

**All parts which are liable to wear are excluded from guarantee.** Furthermore, all deliveries are subject to our "General conditions of delivery and payment", which will be forwarded to you free of charge on request.

### 1.4 Inspection of delivered items

Check the consignment immediately on arrival for damage and conformity with the advice note. In case of damage and/or missing parts, have a report drawn up by the carrier at once.

## 1.5 Instructions for transport and storage

### 1.5.1 Dimensions and weight

A pump or a pump unit is generally too heavy to be moved by hand. Therefore, use the correct transport and lifting equipment. Dimensions and weight of the pump or pump unit are shown on the label on the cover of this manual.

### 1.5.2 Use of pallets

Usually a pump or pump unit is shipped on a pallet. Leave it on the pallet as long as possible to avoid damages and to facilitate possible internal transport.



**When using a forklift always set the forks as far apart as possible and lift the package with both forks to prevent it from toppling over! Avoid jolting the pump when moving it!**

### 1.5.3 Hoisting

When hoisting a pump or complete pump units the straps must be fixed in accordance with figure 1 on page 12.



**When lifting a pump or a complete pump unit always use a proper and sound lifting device, approved to bear the total weight of the load!**



**Never go underneath a load that is being lifted!**



**If the electric motor is provided with a lifting eye, this lifting eye is intended only for the purpose of carrying out service activities to the electric motor! The lifting eye is designed to bear the weight of the electric motor only! It is NOT permitted to lift a complete pump unit at the lifting eye of an electric motor**

## 1.6 Storage

If the pump is not to be used immediately the pump shaft must be turned by hand twice per week.

## 1.7 Ordering parts

This manual contains a survey of the spare parts recommended by Johnson Pump as well as the instructions for ordering them. A fax-order form is included in this manual.

You should always state all data stamped on the type plate when ordering parts and in any other correspondence regarding the pump.



*This data is also printed on the label on the front of this manual.*

If you have any questions or require further information with regard to specific subjects, then do not hesitate to contact Johnson Pump.

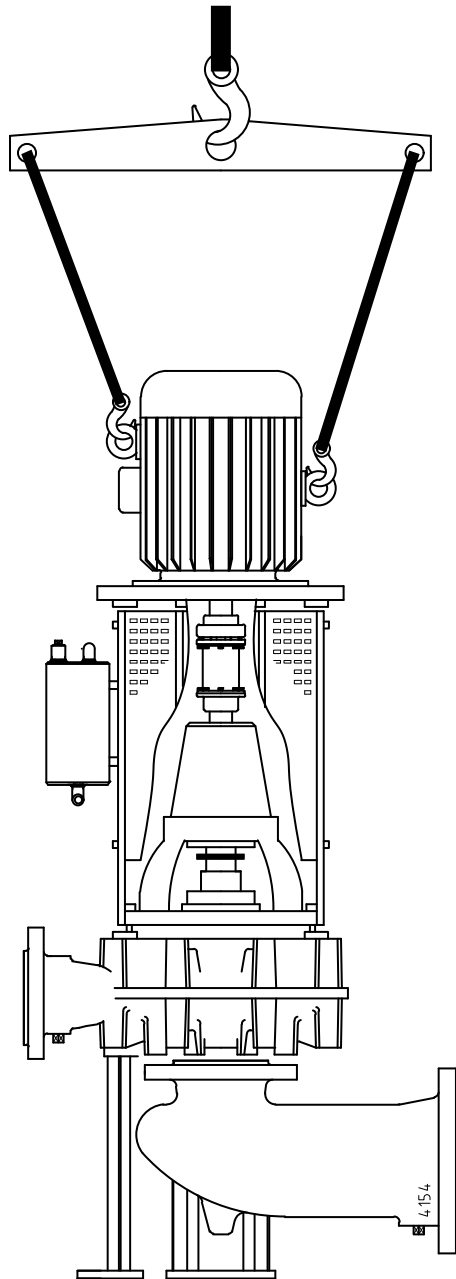

Figure 1: Lifting instructions for pump unit.

## 2 General

### 2.1 Pump description

The CombiPrime V is a range of vertical self-priming centrifugal pumps. Hydraulic application area complies with EN 733 (DIN 24255) (with the exception of CV 250B-315). The flange dimensions, bolt circle and number of holes comply with EN 1092-2 (DIN 2532) ND 10. The CombiPrime V is characterized by the built-in vacuum pump. Thus it is possible to pump fluids mixed with air (gas) or only air during the suction phase. The built-in vacuum pump is based on the liquid ring principle. The pump is driven by a standard IEC flange motor. The power is transmitted through a flexible coupling. Because of their modular lay-out, constructional components are widely interchangeable, also with other pump types of the Combi system.

### 2.2 Type code

Pumps are available in various designs. The main characteristics of the pump are shown in the type code.

Example: **CV 40-200 B2 M2 TL**

pump family		
<b>CV</b>	CombiPrime V	
pump size		
<b>40-200</b>	diameter discharge connection [mm] - nominal impeller diameter [mm]	
pump casing/pump cover and impeller material		
<b>G1</b>	pump casing/pump cover: cast iron	impeller: cast iron
<b>G2</b>	pump casing/pump cover: cast iron	impeller: bronze
<b>G3</b>	pump casing/pump cover: cast iron	impeller: aluminium bronze
<b>B2</b>	pump casing/pump cover: bronze	impeller: bronze
<b>B3</b>	pump casing/pump cover: bronze	impeller: aluminium bronze
shaft sealing		
<b>M2</b>	mechanical seals on shaft sleeves	
<b>M4</b>	tab ring seals on shaft sleeves	
de-aerating unit		
<b>TL</b>	works liquid receiver + air inlet valve	
<b>VL</b>	float de-aerator + air inlet valve	

### 2.3 Application

- In general, this pump can be used for thin, clean or slightly polluted liquids. These liquids should not affect the pump materials.
- The maximum allowed system pressure and temperature and the maximum speed depend on the pump type and the pump construction. For relevant data see paragraph 2.5 "Application area".
- Further details about the application possibilities of your specific pump are mentioned in the order confirmation and/or in the data sheet enclosed with the delivery.
- Please do not use the pump for purposes other than those for which it is delivered without prior consultation with your supplier.



***Using a pump in a system or under system conditions (liquid, working pressure, temperature, etc.) for which it has not been designed may hazard the user!***

### 2.4 Construction

The pump has a modular design. The main components are:

- Pump casing/impeller/suction bend
- Shaft seal
- Self-priming unit
- Bearing
- Lantern construction
- Foot pads

The CombiPrime V pumps are available in 3 bearing bracket groups, meaning that bearing and shaft sealing are divided into 3 groups. Furthermore, the pumps have been standardized in 5 groups featuring the same connection for pump cover and bearing pedestal, depending on the nominal impeller diameters. The pump covers are clamped between the pump casing and bearing bracket.

#### 2.4.1 Pump casing/impeller/suction bend

These are the parts that get into contact with the pumped liquid. For each individual pump type there is only one construction of the pump casing and the impeller. The pump casing and the suction bend are available in cast iron and in bronze, the impeller in cast iron, bronze and aluminium bronze. The pump shaft is available in alloyed and stainless steel. With the available materials the pumps can be supplied in a construction suitable to pump sea water. The square suction bend has been designed in such a way that resistance is low and that all the same a low position of the pump in relation to the floor is possible. The suction bend can be mounted in different positions in relation to the discharge flange. This offers a large number of mounting possibilities.

#### 2.4.2 Shaft sealing

On both sides of the self-priming part there is a mechanical seal or a number of lip seals. Both are mounted on shaft sleeves, which have been sealed in such a way that the pumped liquid cannot touch the pump shaft. The mechanical seals meet EN 12756 (DIN 24960), with the exception of the mounting length. The lip seals are mounted on stainless steel shaft sleeves which have been provided with a hard chromium oxide wearing layer.

2.4.3 Self-priming part

The self-priming part consists of a built-in vacuum pump which is working according to the liquid ring principle, an air-inlet valve with a check valve and a service liquid tank or float controlled air-relief valve. The vacuum pump part is mounted on the pump shaft, but works separately from the centrifugal pump. The service liquid which is supplied to the hub section of the vacuum pump has to maintain the liquid ring. Apart from that, it also serves for cooling and lubrication of the vacuum pump and the shaft seals.

2.4.4 Bearing construction

The bearing construction consists of 2 angular contact ball bearings combined with a cylindrical bearing. The bearings are grease lubricated. The angular contact bearings are mounted in an adjusting sleeve, with which the entire pump shaft can be shifted in order to adjust the axial tolerance of the pump wheel.

2.4.5 Lantern construction

The construction that supports the motor (the lantern) consists of profiled steel elements. The openings between these elements are sealed with perforated steel plate. Pump and motor are coupled by means of a flexible coupling with spacer sleeve ('spacer'). After the guards and spacer have been removed, the rotating part of the pump can be easily dismantled as a whole without having to disconnect the electric motor or the piping. This construction is called the Top-Pull-Out principle.

2.4.6 Foot pads

If the pump has been constructed with foot pads, the pads have to be fastened to the foundation. It is also possible to construct the pump without foot pads and suction bend. In that case, the pump casing is mounted on the foundation and immediately provided with a vertical suction pipe.

2.5 **Application area**

The application area globally looks as follows:

	<b>Maximum value</b>
Capacity	800 m <sup>3</sup> /h
Discharge head	100 m
System pressure	10 bar
Temperature	80°C

However, the maximum allowable pressures and temperatures depend strongly on the selected materials and components. Also working conditions may cause differences.

## 2.6 Re-use

The pump may only be used for other applications after prior consultation with Johnson Pump or your supplier. Since the lastly pumped medium is not always known, the following instructions should be observed:

- Flush the pump properly
- Make sure the flushing liquid is discharged safely (environment!)



***Take adequate precautions and use the appropriate personal protection means (rubber gloves, spectacles)!***

## 2.7 Scrapping

If it has been decided to scrap a pump, the same procedure as for paragraph 2.6 "Re-use" should be followed.

## 3 Installation

### 3.1 Safety

- Read this manual carefully prior to installation and commissioning. Non-observance of these instructions can result in serious damage to the pump and this will not be covered under the terms of our guarantee. Follow the instructions given step by step.
- Ensure that the pump can not be started if work has to be undertaken to the pump during installation and the rotating parts are insufficiently guarded.
- Depending on the design the pumps are suitable for liquids with a temperature of up to 80°C. When installing the pump unit to work at 70°C and above the user should ensure that appropriate protection measures and warnings are fitted to prevent contact with the hot pump parts.
- If there is danger of static electricity, the entire pump unit must be earthed.
- If the pumped liquid is harmful to men or the environment, take appropriate measures to drain the pump safely. Possible leakage liquid from the shaft seal should also be discharged safely.

### 3.2 Preservation

In order to prevent corrosion, the inside of the pump is treated with a preserving agent before leaving the factory.

Before commissioning the pump remove any preserving agents and flush the pump thoroughly with hot water.

### 3.3 Environment

- The foundation must be hard, level and flat.
- The area in which the pump is installed must be sufficiently ventilated. An ambient temperature or air humidity which is too high, or a dusty environment, can have a detrimental effect on the operation of the electric motor.
- There should be sufficient space around the pump unit to operate and if necessary repair it.
- Behind the cooling air inlet of the motor there must be a free area of at least 1/4 of the electric motor diameter, to ensure unobstructed air supply.

### **3.4 Mounting**

#### **3.4.1 Installation of a pump unit**

Pump and motor shafts of complete pump units are adjusted perfectly in line in the works.

- 1 In case of permanent arrangement place the base plate level on the foundation with the aid of shims.
- 2 Carefully tighten the nuts on the foundation bolts.
- 3 Check the alignment of pump and motor shafts and if necessary realign, see paragraph 3.4.3 "Alignment of the coupling".

#### **3.4.2 Assembling a pump unit**

If the pump and the electric motor still have to be assembled, do the following:

- 1 Remove the front guards (0270). Check if there is a key in both shaft ends.
- 2 Clean the motor and pump shaft. Grease both shaft ends with mounting grease.
- 3 Mount the flattened coupling part on the pump shaft (2200). Keep the coupling part in line with the pump shaft end and fasten the coupling with the locking screw.
- 4 Fix the other coupling half on the motor shaft.
- 5 Place the electric motor on the flange (0260). Secure the electric motor with bolts and nuts (0850). Push the coupling half on the motor shaft upward.

➤ *Wherever possible use a hoisting machine and the crane hooks on the electric motor.*

- 6 Mount the distance sleeve on the lower coupling half.
- 7 Push the upper coupling half downward. For the correct distance between the coupling halves, see figure 2 with the corresponding table. Then secure the coupling half on the motor shaft.
- 8 Check whether the coupling can be turned by hand. Check the alignment, see paragraph 3.4.3 "Alignment of the coupling".
- 9 Mount the guards.

3.4.3 Alignment of the coupling

- 1 Use bolts (0890) to position the electric motor in such a way that the coupling halves are aligned correctly.
- 2 Place a ruler against the coupling. The ruler should touch both coupling halves across the whole width. See figure 2A.
- 3 Do this check a couple of times around the entire coupling.

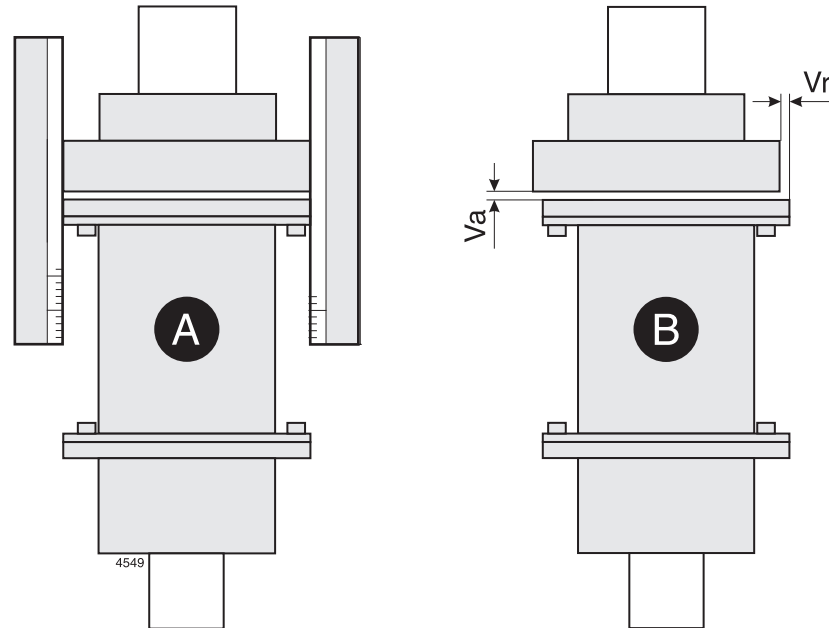

Figure 2: Alignment of the coupling.

The maximum allowable tolerances in the alignment of the coupling halves are shown in the table below. See figure 2B.

Outer diameter coupling [mm]	Va		Vrmax [mm]
	min [mm]	max [mm]	
81-95	5	6	0,15
96-110	5	6	0,18
111-130	5	6	0,21
131-140	5	6	0,24
141-160	6	7	0,27
161-180	6	7	0,30
181-200	6	7	0,34
201-225	6	7	0,38
225-250	7	9	0,42
251-280	7	9	0,47

### 3.5 Piping

- The piping to the suction and delivery connections must fit exactly and must not be subject to stress during operation.
- The passage of the suction pipe must be amply dimensioned. This pipe should be as short as possible and run towards the pump in such a way that no air pockets can arise. If this is not possible, a venting facility should be provided at the highest point of the pipe.
- If the inside diameter of the suction pipe is larger than the suction connection of the pump, an eccentric reducer should be applied to prevent air pockets and whirls. See figure 3.

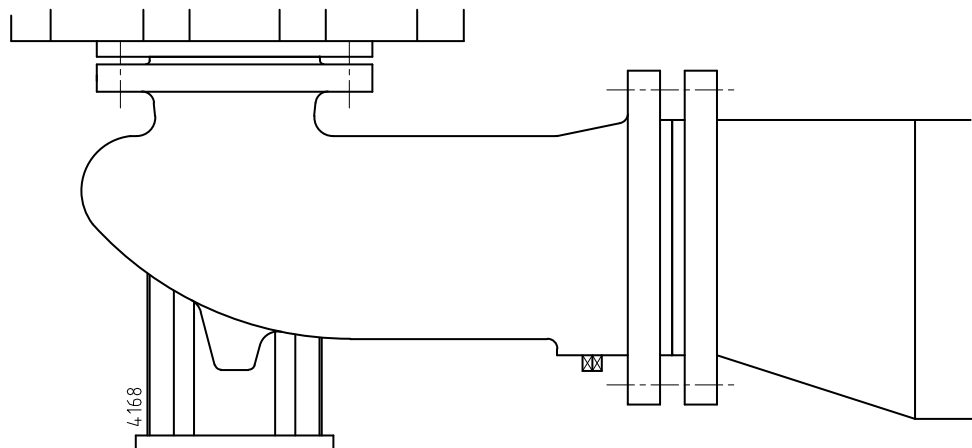

Figure 3: Eccentric reducer to suction flange.

- Sudden changes in the rate of flow can lead to high pressure impulses in the pump and the piping (water shock). Therefore, do not use quick-acting closing devices, valves etc.

### 3.6 Accessories

- It is recommended to always mount a check valve and a shut-off valve in the suction pipe, as close as possible to the pump. If there is no check valve, the pump can only be started with closed delivery valve.
- In case of possible pre-pressure on the suction side, mount a shut-off valve in the suction pipe.
- If necessary, mount a foot valve at the bottom of the suction pipe. Combine this foot valve with a suction strainer to prevent impurities from being drawn in.
- When mounting, place temporarily (for the first 24 operating hours) a fine gauze between suction flange and suction pipe so as to prevent internal pump parts from being damaged by foreign matter. If the risk of damage continues to exist, mount a permanent filter.
- Fit any parts that may have been supplied separately.

**3.7 Vacuum pump with service liquid tank**

3.7.1 Mounting of accessories

- Connect a pipe to the overflow of the service liquid tank to discharge excess service liquid and extracted air.
- The pump is supplied with the exhaust pipe connected to the pump cover.

3.7.2 Connection diagram with service liquid tank

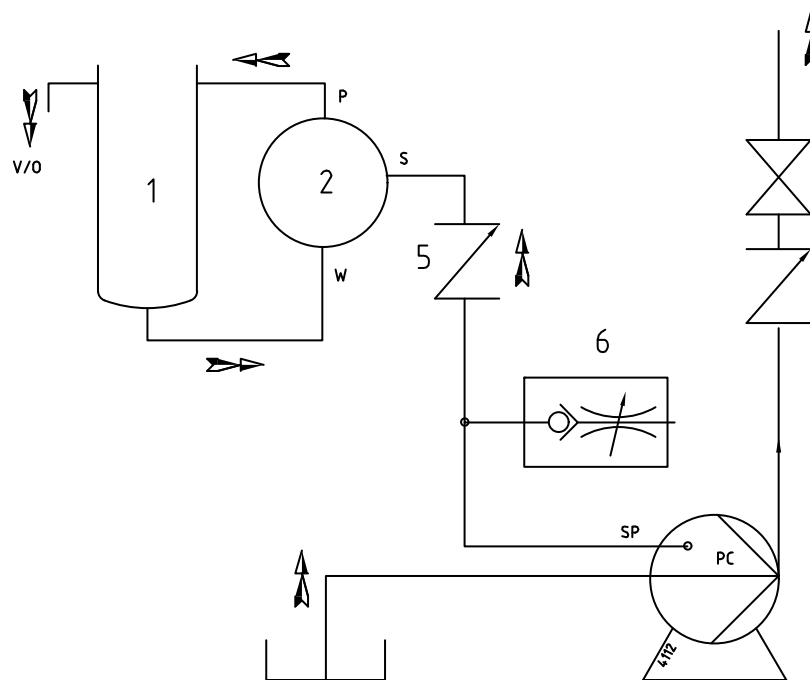

Figure 4: Connection diagram with service liquid tank.

3.7.3 Indication of connections

The suction, delivery and service liquid connections of the vacuum pump are indicated both on the drawings and on the vacuum pump by the letters **S**, **P** and **W**. Suction point **PC** is the connection to the space behind the impeller.

Indications used in figure 4 through figure 8:

<b>V/O</b>	Venting / Overflow
<b>S</b>	Inlet vacuum pump
<b>SP</b>	Exhaust pipe
<b>P</b>	Outlet vacuum pump
<b>W</b>	Service liquid
<b>PC</b>	Pump connection (=air-extraction connection centrifugal pump)
<b>SF</b>	Filter in suction pipe (only in figure 6)
<b>1</b>	Service liquid tank
<b>2</b>	Vacuum pump
<b>5</b>	Check valve
<b>6</b>	Air inlet valve

### 3.7.4 Installation examples with service liquid tank

For a few situations is shown how pumps with a service liquid tank can be installed.

**!** **Excess service liquid must always be discharged to the suction tank separately.**

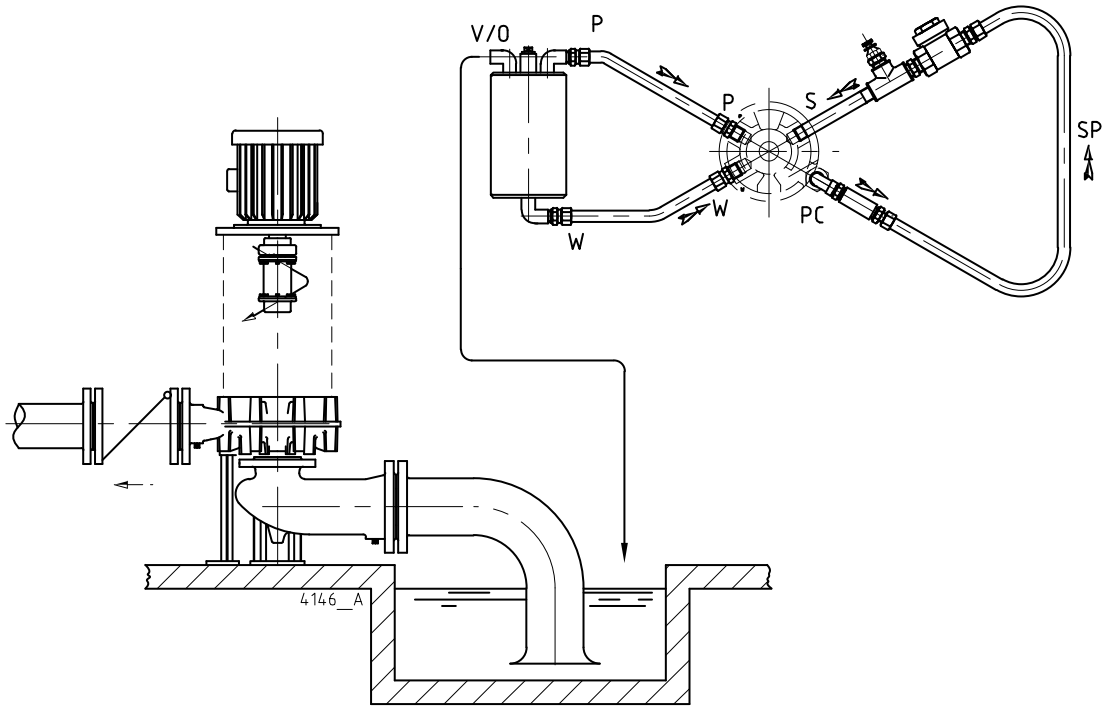

Figure 5: *Medium: thin, clean and slightly polluted liquids.*

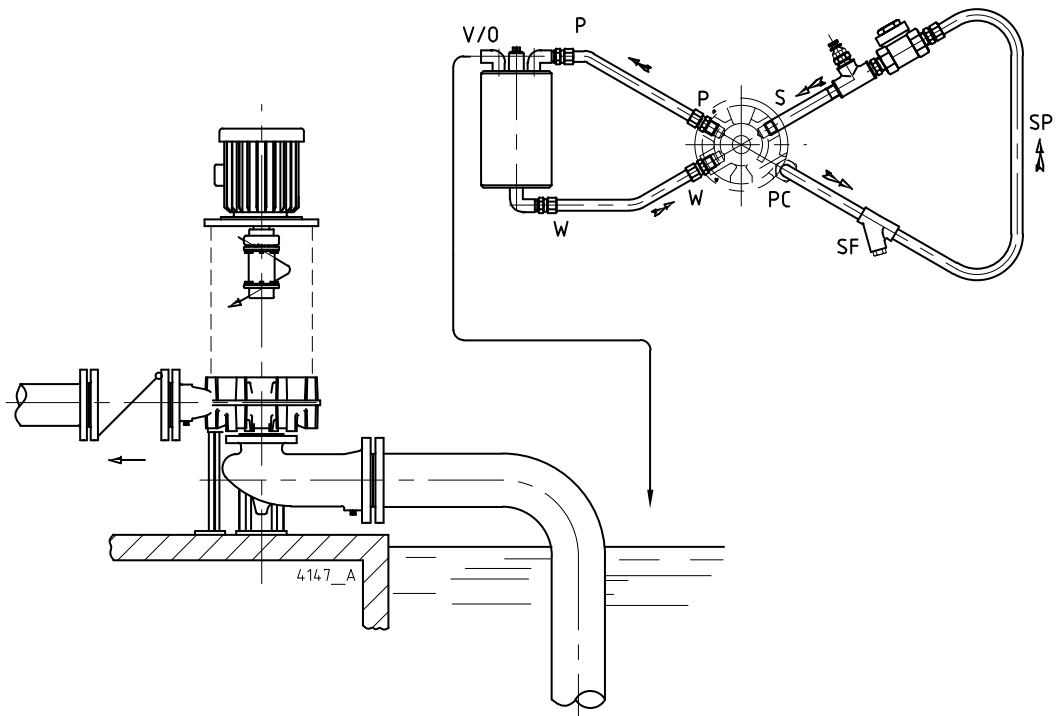
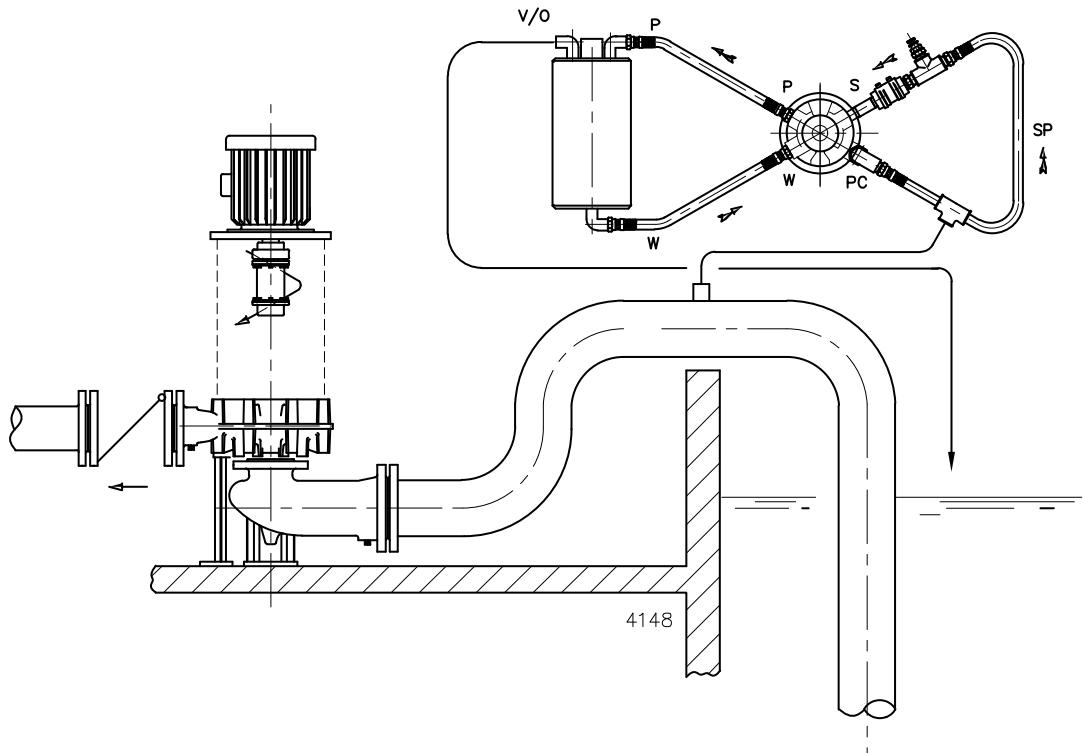

Figure 6: *Medium: thin liquids, polluted with highly abrasive constituents. The back blades on the centrifugal impeller prevent heavy abrasive matter from getting into the suction space behind the impeller. To prevent floating abrasive matter from penetrating the pump, mount a filter in the suction pipe. The straining capacity of the filter should correspond with the nature of the pollutants. If necessary, mount several filters with different sieve sizes behind each other. Use at least one filter with Rp 3/4" connections and a sieve size of 0,6 mm.*

**!** **Clean the filters regularly.**



*Figure 7: Medium: thin, clean and slightly polluted liquids. In case part of the suction pipe lies higher than the pump, venting should also be provided in this part. If the suction pipe is short, or the lift in the suction pipe small, venting at the highest point is not necessary. However, the suction time will be longer.*

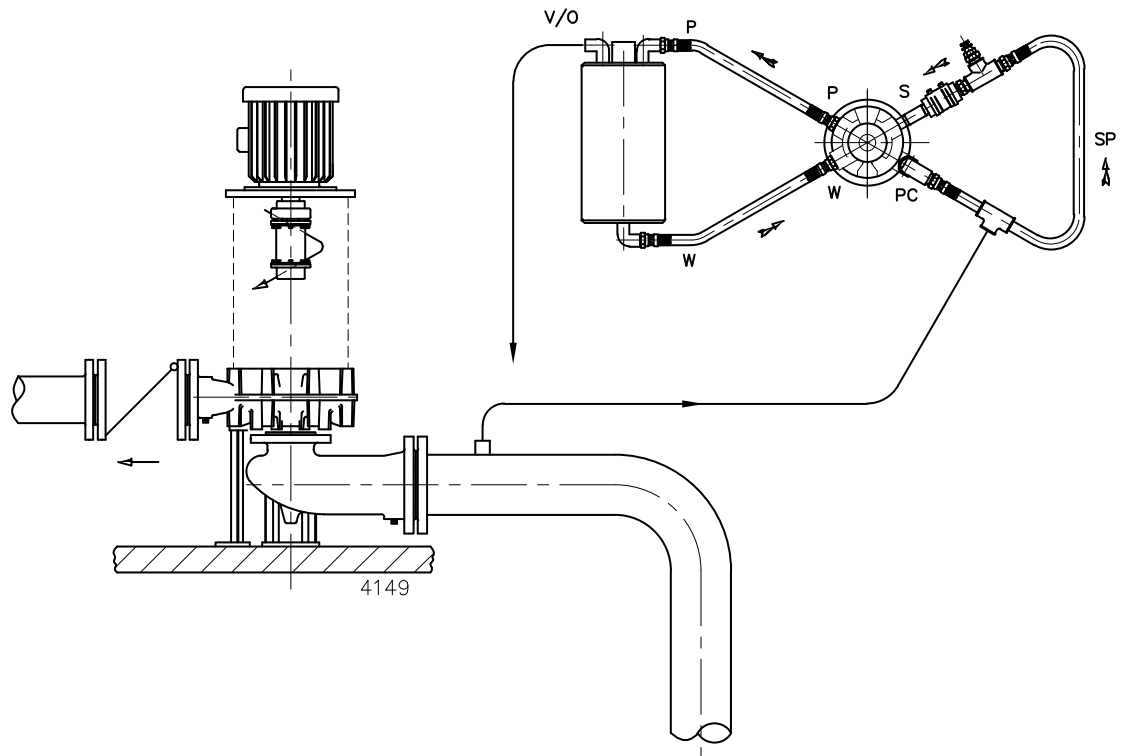

Figure 8: *Medium: thin, clean and slightly polluted liquids. In case of long suction pipes (10 m or more) and a high suction head (4-7 m), also the suction pipe must be vented.*

### 3.8 Vacuum pump with float-controlled de-aerator

#### 3.8.1 Mounting of accessories

- Connect the exhaust pipe of the float-controlled de-aerator to the suction pipe. The passage of the exhaust pipe must be approx. 12 mm and the connection to the suction pipe at least G1/2".
- The pump is supplied with the exhaust pipe connected to the pump cover.

#### 3.8.2 Connection diagram with float-controlled de-aerator

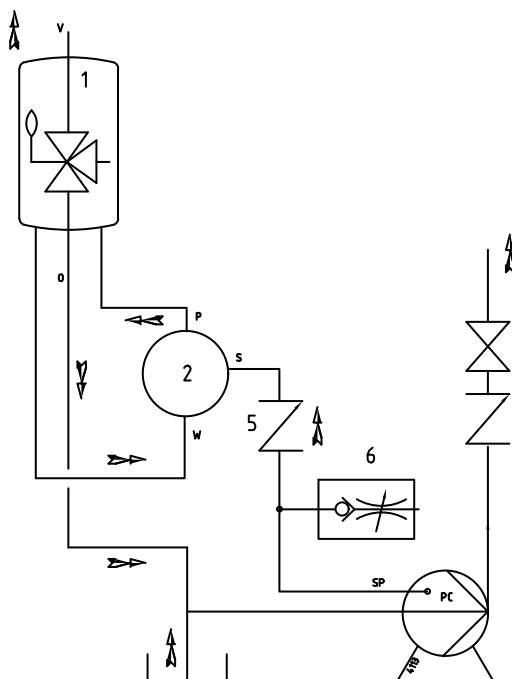

Figure 9: Connection diagram with float-controlled de-aerator.

#### 3.8.3 Indication of connections

The suction, delivery and service liquid connections of the vacuum pump are indicated both on the drawings and on the vacuum pump by the letters **S**, **P** and **W**. Suction point **PC** is the connection to the space behind the impeller.

Indications used in figure 9 through figure 13:

<b>V/O</b>	Venting / Overflow
<b>S</b>	Inlet vacuum pump
<b>SP</b>	Exhaust pipe
<b>P</b>	Outlet vacuum pump
<b>W</b>	Service liquid
<b>PC</b>	Pump connection (=air-extraction connection centrifugal pump)
<b>SF</b>	Filter in exhaust pipe (only in figure 11)
<b>1</b>	Float-controlled de-aerator
<b>2</b>	Vacuum pump
<b>5</b>	Check valve
<b>6</b>	Air inlet valve

3.8.4 Installation examples with float-controlled de-aerator

For a few situations is shown how pumps with a float-controlled de-aerator can be installed.

**!** The excess service liquid is always returned to the suction pipe.

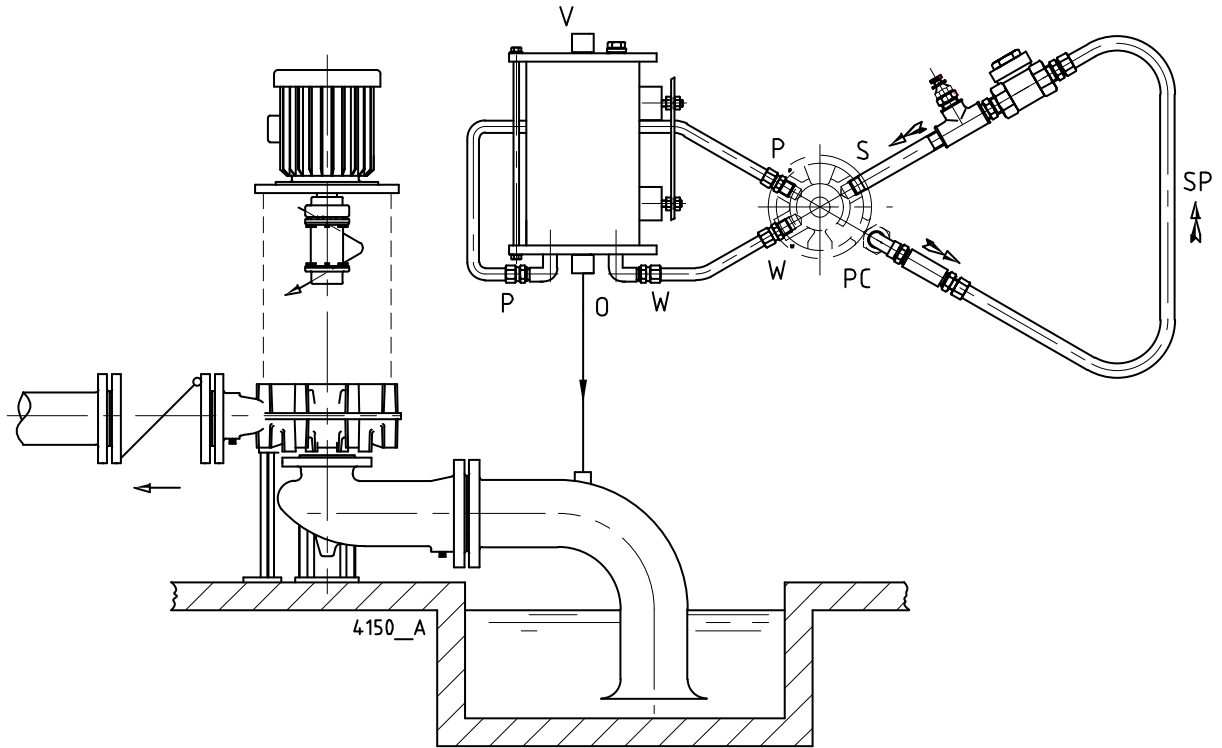

Figure 10: Medium: thin, clean and slightly polluted liquids.

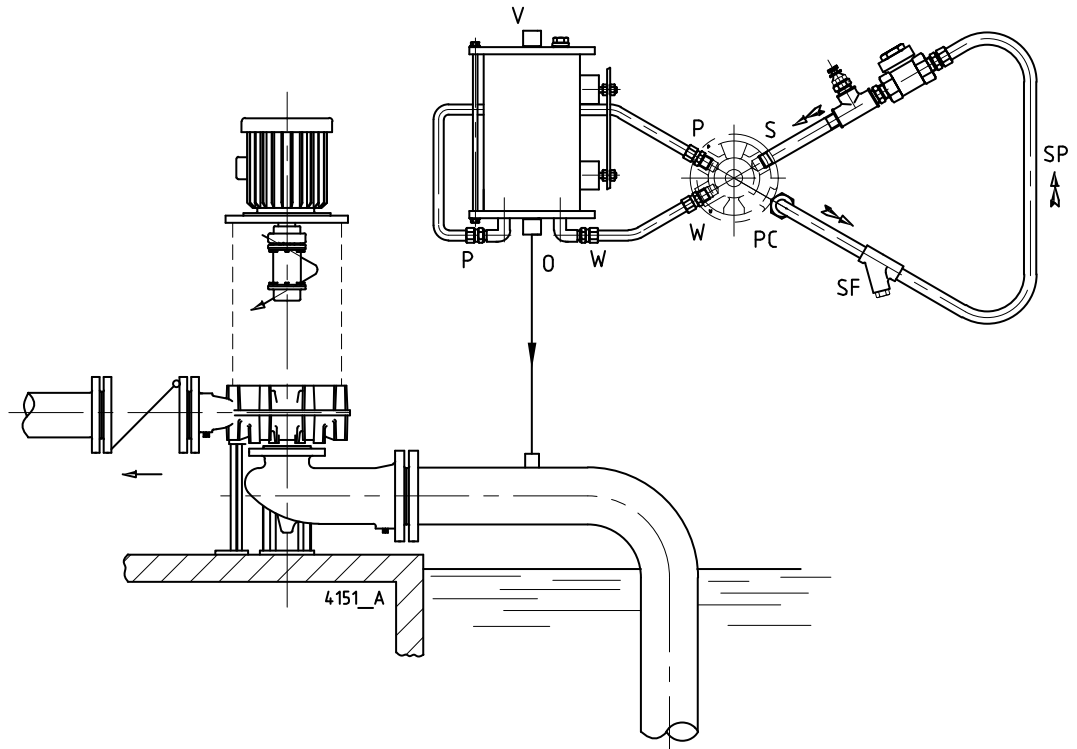

Figure 11: *Medium: thin liquids polluted with highly abrasive matter. The back blades on the centrifugal impeller prevent heavy abrasive matter from getting into the suction space behind the impeller. To prevent floating abrasive matter from penetrating the pump, mount a filter in the suction pipe. The straining capacity of the filter should correspond with the nature of the pollutant. If necessary, mount several filters with different sieve sizes behind each other. Use at least one filter with Rp 3/4" connections and a sieve size of 0,6 mm.*

**!** **Clean the filters regularly.**

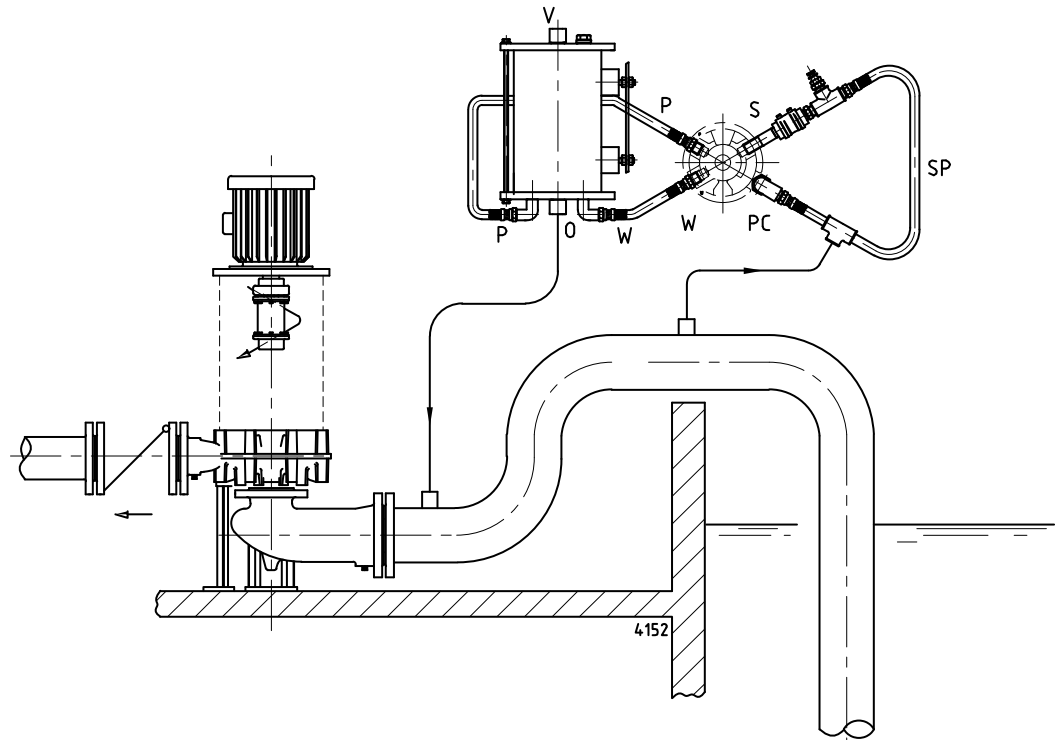

Figure 12: *Medium: thin, clean and slightly polluted liquids. In case part of the suction pipe lies higher than the pump, venting should also be provided in this part. If the suction pipe is short, or the lift in the suction pipe small, venting at the highest point is not necessary. However, the suction time will be longer.*

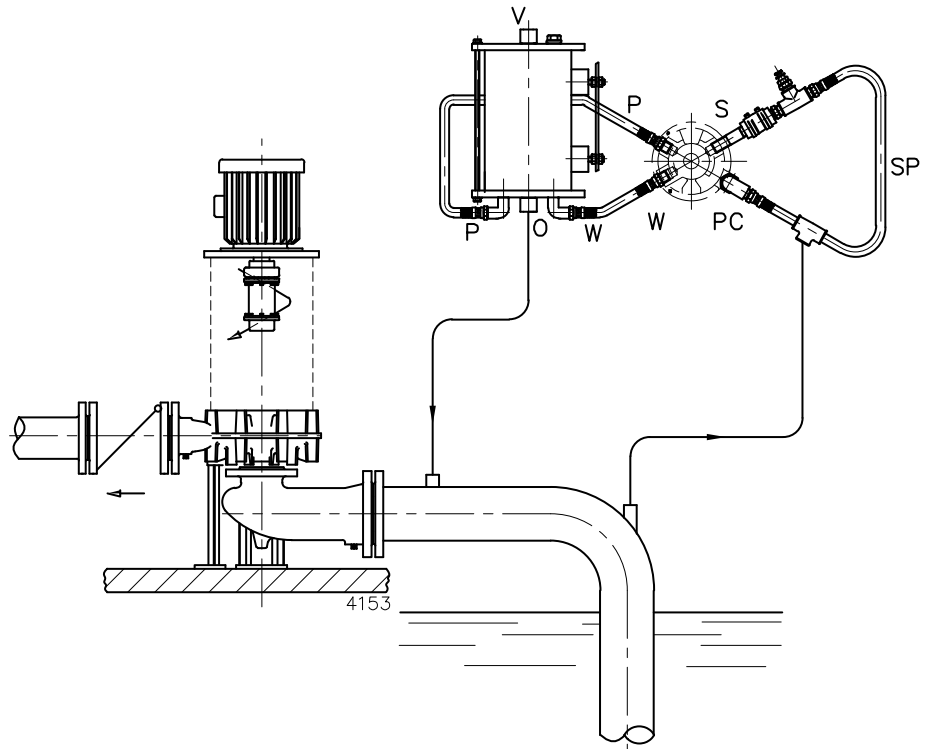

Figure 13: *Medium: thin, clean and slightly polluted liquids. In case of long suction pipes (10 m or more) and a high suction head (4 -7 m), also the suction pipe must be vented.*

### 3.9 Connection of the electric motor



**The electric motor must be connected to the mains by an approved electrician, according to the locally prevailing regulations of the electricity company.**

- Refer to the instruction manual belonging to the electric motor.
- If possible, fit a working switch as close as possible to the pump.

## 4 Commissioning

### 4.1 Inspection of the pump

Check whether the pump shaft turns freely. Do this by turning the shaft end at the coupling a few times by hand.

### 4.2 Inspection of the vacuum pump part

- 1 Check whether all piping between the pump wheel casing and the service liquid tank (version TL) or the float-controlled de-aerator (version VL) have been connected.
- 2 Fill the service liquid tank or the float-controlled de-aerator with liquid and close them with plug (1690) or (3013) respectively.

### 4.3 Inspection of the motor

Check whether the fuses have been mounted.

### 4.4 Checking the sense of rotation



***Beware of possible non-screened rotating parts, when checking the sense of rotation!***

- 1 The sense of rotation of the pump is indicated by an arrow. Check whether the sense of rotation of the motor corresponds with that of the pump.
- 2 Let the motor run for only a short time and check the sense of rotation.
- 3 If the sense of rotation is **not** correct, alter the sense of rotation. See the instructions in the user manual belonging to the electric motor.
- 4 Fit the guard.

### 4.5 Start-up

Proceed as follows, both when the pump is put into operation for the first time and when it is re-mounted after repairs.

- 1 Close the air-inlet valve (1650).
- 2 Fully open the stop valve in the suction pipe. Close the delivery stop valve.
- 3 Start the pump.
- 4 As soon as the pump is under pressure, slowly open the delivery stop valve until the working pressure is attained.



***Make sure that when a pump is running, rotating parts are always properly screened off by the guards!***

#### **4.6 Adjusting the air-inlet valve**

The air-inlet valve (1650) serves to admit small quantities of air into the self-priming system. The vacuum pump has been designed to pump a large quantity of air. After the suction phase, the vacuum pump functions as liquid pump. However, in principle it is not designed to only pump liquid. By adding a small quantity of air through the air-inlet valve, it is possible to avoid problems. After the pump has been started with closed air-inlet valve, the valve is adjusted as follows:

- 1 When the suction phase is over and the centrifugal pump maintains the liquid flow on its own, the pump will start making a crackling noise.
- 2 Slowly open the air-inlet valve until the crackling stops.
- 3 Leave the valve in this position and secure it with a lock nut. The valve is now properly adjusted. Provided the system conditions do not change, the pump can be reconnected after a break without having to readjust the valve.

#### **4.7 Mechanical seal**

The mechanical seals nor the lip seals may never show any visible leakage.

#### **4.8 Pump in operation**

When the pump is in operation, pay attention to the following:

- The pump may never run without liquid in the service liquid tank or the float-controlled de-aerator.
- Never use a stop valve in the suction line to control pump output. The stop valve should always be fully opened during operation.
- Check whether the absolute inlet pressure is sufficient, to prevent vaporization in the pump.
- Check whether the pressure difference between suction and delivery side corresponds with the specifications of the pump's duty point.

#### **4.9 Noise**

The noise production of a pump depends to a great extent on the operating conditions. The values stated in paragraph 10.5 "Noise data" are based on normal operation of the pump, driven by an electric motor. In case the pump is used outside the normal operation area, as well as in case of cavitation, the noise level may exceed 85 dB(A). In that case precautions should be taken, like building a noise-barrier around the unit or wearing hearing protection.

## 5 Maintenance

### 5.1 Daily maintenance

Regularly check the outlet pressure.



***No water should get into the terminal box of the electric motor when the pump room is sprayed clean! Never spray water on hot pump parts! The sudden cooling down may cause them to burst and hot water may flow out!***

### 5.2 Service liquid

After the pump has been put into operation once, the working-liquid tank and the float-controlled de-aerator don't have to be filled up again: there is constantly a sufficient quantity of pumped liquid in the working-liquid tank and the float-controlled de-aerator.

### 5.3 Shaft sealing

#### 5.3.1 Mechanical seal

A mechanical seal generally requires no maintenance, however, **it should never be allowed to run dry**. If there are no problems, do not dismantle the mechanical seal. As the seal faces have run in on one another dismantling usually implicates replacement of the mechanical seal. If a mechanical seal shows any leakage it has to be replaced.

#### 5.3.2 Lip seal

The lip seals generally require no maintenance. The lip seals run around stainless steel shaft sleeves which are provided with a hard wearing layer. The space between the lip seals is filled with grease when they are mounted, so as to limit wearing to a minimum. When the lip seals are leaking they have to be replaced.

### 5.4 Lubrication of the bearings

The bearings have to be re-greased after every 1000 hours of operation. The bearings are greased before delivery. In case the pump is overhauled, the bearings and the bearing house have to be cleaned and provided with new grease. See paragraph 10.1 "Recommended greases" for recommended greases and quantities to be applied.

### 5.5 Environmental influences

- Regularly clean the filter in the suction pipe or the suction strainer at the bottom of the suction pipe, as the inlet pressure may become too low if the filter or the suction strainer is fouled.
- If there is a risk that the pumped liquid expands during solidification or freezing, the pump has to be drained and, if necessary, flushed after it has been put out of service.
- If the pump is out of service for a long time, it has to be preserved.

### 5.6 Noise

If a pump starts making noise, this may point to certain problems with the pump unit. A crackling noise can indicate cavitation or excessive motor noise can indicate deterioration of the bearings.

### 5.7 Faults



***The pump, of which you want to determine the fault, may be hot or under pressure. Take the appropriate precautions first and protect yourself with the proper safety devices (safety goggles, gloves, protective clothing)!***

To determine the source of the malfunctioning of the pump, proceed as follows:

- 1 Switch off the power supply to the pump unit. Lock the working switch with a padlock or remove the fuse.
- 2 Close the stop valves.
- 3 Determine the nature of the fault.
- 4 Try to determine the cause of the fault with chapter 6 "Problem solving" and take the appropriate measures or contact your installer.

## 6 Problem solving

Faults in a pump installation can have various causes. The fault may not be in the pump, it may also be caused by the pipe system or the operating conditions. Firstly, always check that installation has been executed in accordance with the instructions in this manual and that the operating conditions still correspond with the specifications for which the pump was purchased.

In general, breakdowns in a pump installation are attributable to the following causes:

- Faults with the pump.
- Breakdowns or faults in the pipe system.
- Faults due to incorrect installation or commissioning.
- Faults due to incorrect choice of pump.

A number of the most frequently occurring failures as well as their possible causes are shown in the table below.

<b>Most common faults</b>	<b>Possible causes</b>
Pump delivers no liquid	1 4 8 9 10 11 13 14 17 19 20 21 29
Pump has insufficient volume flow	2 3 4 8 9 10 11 13 14 15 17 19 20 21 28 29 44
Pump has insufficient head	2 4 13 14 17 19 28 29
Pump stops after start up	1 8 9 10 11
Pump has higher power consumption than normal	12 15 16 17 18 22 23 24 25 26 27 32 34 38 39
Pump has lower power consumption than normal	3 14 15 16 17 18 20 21 28 29 44
Mechanical seals have to be replaced to often	23 25 26 30 32 33 34
Pump vibrates or is noisy	9 10 11 15 18 19 20 22 23 24 25 26 27 29 37 38 39 40 43
Bearings wear too much or become hot	23 24 25 26 27 37 38 39 40 42
Pump running rough hot or seizes	23 24 25 26 27 34 37 38 39 40 42

	<b>Possible causes</b>
<b>1</b>	Service liquid tank or float de-aerator not filled with liquid
<b>2</b>	Gas or air coming from the liquid
<b>3</b>	Air lock in the suction pipe
<b>4</b>	Suction pipe leaks air
<b>8</b>	The manometric suction head is too high
<b>9</b>	Suction pipe or suction strainer is blocked
<b>10</b>	Insufficient immersion of foot valve or suction pipe during operation of the pump
<b>11</b>	NPSH available too low
<b>12</b>	Speed too high
<b>13</b>	Speed too low
<b>14</b>	Wrong sense of rotation
<b>15</b>	Pump doesn't work at the right duty point
<b>16</b>	Liquid density differs from the calculated liquid density
<b>17</b>	Liquid viscosity differs from the calculated liquid viscosity
<b>18</b>	Pump works when the liquid flow is too low
<b>19</b>	Wrong pump selection
<b>20</b>	Obstruction in impeller or pump housing
<b>21</b>	Obstruction in the piping
<b>22</b>	Wrong installation of the pump unit
<b>23</b>	Pump and motor not well aligned
<b>24</b>	Rotating part running out of true
<b>25</b>	Imbalance in rotating parts e.g. impeller pump shaft coupling
<b>26</b>	Pump shaft is running out of true
<b>27</b>	Bearings faulty or worn out
<b>28</b>	Sealing rings faulty or worn out
<b>29</b>	Damaged impeller
<b>30</b>	Running surfaces of the mechanical seals
<b>32</b>	Bad mounting of the mechanical seals or of the lip seals
<b>33</b>	Mechanical seals or lip seals not suitable for the operation liquid or operation circumstances
<b>34</b>	Pump wheel cover not perpendicularly mounted
<b>37</b>	Axial retaining of impeller or pump shaft is defective
<b>38</b>	The bearings have been mounted wrongly
<b>39</b>	Too much or too little bearing lubrication
<b>40</b>	Wrong or polluted lubricant
<b>42</b>	Too high axial force because of worn dorsal blades or excessive inlet pressure
<b>43</b>	Air-inlet valve closed
<b>44</b>	Air-inlet valve opened too much

# 7 Disassembly and assembly

## 7.1 Precautionary measures



**Take adequate measures to avoid that the motor is started while you are working on the pump. This is especially important for electric motors with remote control:**

- Switch the operating switch near the pump (if available) to "OFF".
- Switch off the pump switch on the switchboard.
- If necessary remove the fuses.
- Hang a danger board near the switchboard cabinet.

## 7.2 Tools

Assembly and disassembly work requires no special tools. However such tools can make certain jobs easier, for instance replacing the shaft seal. If such is the case it will be indicated in the text.

## 7.3 Liquid draining

Drain the pump through drain plug (0350). If applicable, close all valves in the suction and delivery piping and in the flushing and cooling pipe to the shaft seal. Also drain the self-priming section by disconnecting the piping P, S and W.

If the pump processes harmful liquids, take the following precautionary measures:

- 1 Wear protective gloves, glasses, etc..
- 2 Flush the pump properly.
- 3 Make sure no liquid gets into the environment.
- 4 Refit the drain plug.

## 7.4 Item numbers

If no specific figure numbers are stated, then the item numbers used in these instructions refer to the cross section drawings and parts lists, which can be found in chapter 9.

The connection markings P, S and W on the self-priming section are explained in paragraph 3.7.3 "Indication of connections" for the Service liquid tank configuration TL or paragraph 3.8.3 "Indication of connections" for the Float Deaerator configuration VL.

## 7.5 Construction variants

The pumps are supplied in 2 construction variants and with 2 processing liquid devices. The variants have a special code, which is stated in the type designation on the type plate on the pump.

<b>M2</b>	mechanical shaft seals on shaft sleeves
<b>M4</b>	lip seals on hardened shaft sleeves
<b>TL</b>	processing liquid tank and air-inlet valve
<b>VL</b>	float-operated de-aerator and air-inlet valve

## 7.6 Top-Pull-Out system

The pumps are designed with a Top-Pull-Out system. By using the spacer-coupling the intermediate piece of this coupling can easily be removed. After that, the bearing bracket with the entire rotating part can be removed. This means that the pump can be disassembled to a major extent without having to disconnect the suction and delivery piping. The motor can remain in its place.

### 7.6.1 Disassembly Top-Pull-Out unit

- 1 Disconnect the connections **S**, **P** and **W** from the pump wheel casing.
- 2 Remove the guards (0270).
- 3 Remove the distance sleeve (0210) of the spacer coupling.
- 4 Mark the position of the pump cover (0110) and the bearing bracket (2100) in relation to the pump casing (0100).
- 5 Remove the Allen screws (0800) and lift the Top-Pull-Out unit out of the pump through the opening between the lantern elements (0250).



***The unit is too heavy to be lifted by hand. Therefore, use appropriate hoisting equipment.***

### 7.6.2 Assembly Top-Pull-Out unit

- 1 Mount a new gasket for the pump casing (0300) and lift the Top-Pull-Out unit in the right position into the pump casing.



**Take care not to damage the gasket (0300).**

- 2 Tighten the Allen screws (0800) crosswise.
- 3 Reconnect the connections **S**, **P** and **W** to the pump wheel casing.
- 4 Mount the distance sleeve of the spacer coupling (0210).
- 5 Check the alignment of pump and motor shaft, see paragraph 3.4.3 "Alignment of the coupling". If necessary realign.
- 6 Mount the guards (0270).

**7.7 Replacement of impeller and wear ring**

The play between the impeller and the wear ring is 0,3 mm to the diameter at delivery. In case the play has increased to 0,5-0,7mm due to wearing, the impeller and the wear ring should be replaced.

**7.7.1 Disassembly of the impeller**

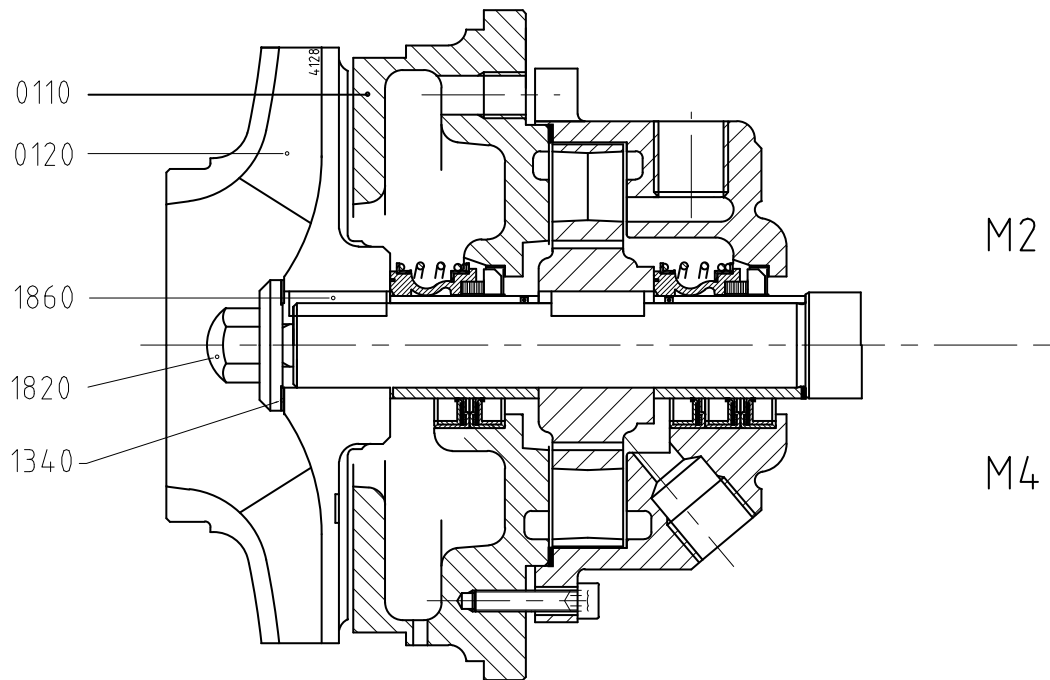

Figuur 14: Disassembling the impeller.

The item numbers used are referring to figure 14.

- 1 Remove the Top-Pull-Out unit, see paragraph 7.6.1 "Disassembly Top-Pull-Out unit".
- 2 Remove the impeller cap nut (1820) with the gasket (1340). Sometimes the nut has to be heated to break the Loctite-contact.
- 3 Remove the impeller (0120) with a pulley puller or wrest the impeller loose by inserting for instance 2 big screwdrivers between the impeller and the pump cover (0110).
- 4 Remove the impeller key (1860).
- 5 Remove the gasket (1940).

**7.7.2 Assembly of the impeller**

- 1 Mount the gasket (1940).
- 2 Place the impeller key in the key way of the pump shaft.
- 3 Push the impeller onto the pump shaft against the gasket (1940).
- 4 Degrease the thread on the pump shaft and the thread in the impeller nut.
- 5 Put a drop of Loctite 243 on the thread and mount the gasket (1340) and the impeller cap nut (1820). For tightening moment of the nut see the table in paragraph 10.3.2 "Tightening moments for cap nuts".
- 6 Mount the Top-Pull-Out unit, see paragraph 7.6.2 "Assembly Top-Pull-Out unit".

### 7.7.3 Disassembly of the wear ring

After removing the Top-Pull-Out unit the wear ring can be removed. In most cases the ring has been fixed so tightly that it cannot be removed undamaged.

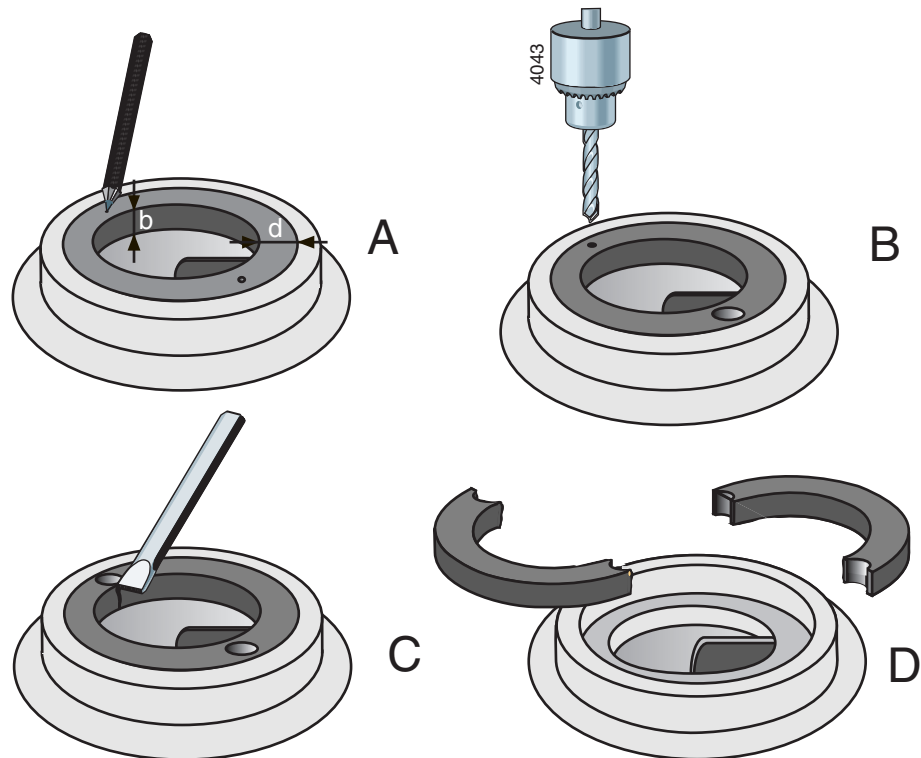

Figure 15: Removal of wear ring.

- 1 Measure the thickness (d) and the width (b) of the ring, see figure 15 A.
- 2 Make a centre hole in the middle of the edge of the ring at two opposite points, see figure 15 B.
- 3 Use a drill with a diameter just a little bit smaller than the thickness (d) of the ring and drill two holes in the ring, see figure 15 C. Don't drill deeper than the width (b) of the ring. Take care not to damage the fitting edge of the pump casing.
- 4 Use a chisel to cut the remaining part of the ring thickness. Now you can remove the ring in two parts from the pump casing, see figure 15 D.
- 5 Clean the pump casing and carefully remove all bore dust and metal splinters.

### 7.7.4 Assembling the wear ring

- 1 Clean and degrease the fitting edge of the pump casing where the wear ring is to be mounted.
- 2 Degrease the outer edge of the wear ring and put a few drops of Loctite 641 on it.
- 3 Fit the wear ring in the pump casing. **Take care it is not pushed out of alignment!**

**7.8 Shaft sealing**

7.8.1 Disassembly of the mechanical seals M2

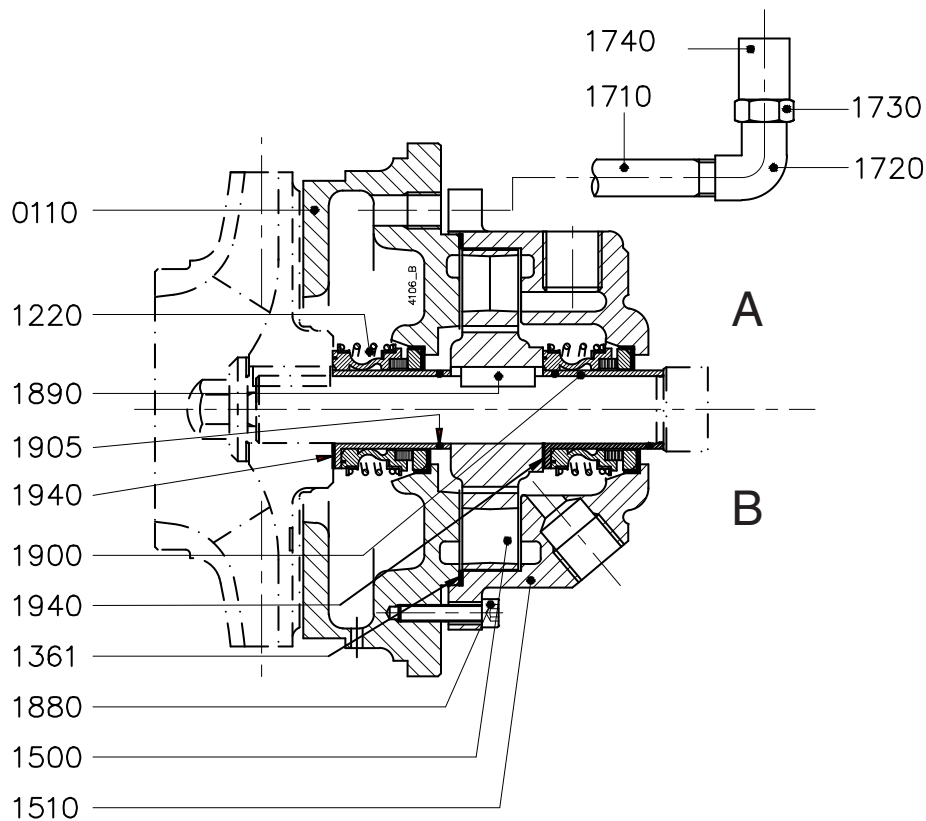

Figure 16: Mechanical seal M2  
(A = bearing groups 1 and 2, B = bearing group 3).

The item numbers used are referring to figure 16.

- 1 Disassemble the impeller, see paragraph 7.7.1 "Disassembly of the impeller".
- 2 Pull the shaft sleeve (1900) off the pump shaft and remove the rotating part of the mechanical seal from the shaft sleeve.  
Bearing group 3 only: Remove gasket (1940).
- 3 Mark the position of the pump cover (0110) in relation to the bearing bracket (2100).
- 4 Loosen the Allen screws (1880).
- 5 Push the cover of the pump wheel casing (1510) backward.
- 6 Knock the pump cover loose and push it off the pump shaft. Press the counter-ring of the mechanical seal out of it.
- 7 Pull the pump wheel (1500) from the pump shaft and remove the key (1890).
- 8 Pull the shaft sleeve (1900) from the pump shaft and remove the rotating part of the mechanical seal from the shaft sleeve.  
Bearing group 3 only: Remove gasket (1940).
- 9 Push the cover of the pump wheel casing (1510) off the pump shaft and press the counter-ring out.
- 10 Remove gasket (1361).
- 11 Remove O-rings (1905) out of the shaft sleeves (1900).

### 7.8.2 Instructions for mounting a mechanical seal

➤ *First read the following instructions regarding the mounting of a mechanical seal. Follow these instructions closely when mounting a mechanical seal.*

- A mechanical seal is a fragile precision part. Leave the seal in its original packing until you are ready to fit it!
- Clean all receiving parts properly. Make sure your hands and working environment are clean!
- **Never touch the sliding surfaces with ones fingers!**
- Never put the rings down on their sliding surfaces!

### 7.8.3 Assembly of the mechanical seals M2

- 1 Check the shaft sleeves (1900) and the splash ring (2220) for damages. Also, the splash ring should clasp the shaft well. If necessary replace these parts.
- 2 Place the bearing bracket with the shaft upright.
- 3 Place the cover of the pump wheel casing (1510) and the pump cover (0110) flat down and press the counter-rings of the shaft seals straight into the. If necessary use a plastic pressure piece. Never knock them inside! The maximum axial turn of the counter-ring is 0,1 mm.
- 4 Put some glycerine or silicon grease on the O-rings and mount the O-rings into the shaft sleeves.
- 5 Push the cover of the pump wheel casing (1510) over the pump shaft.
- 6 Wet the clean shaft sleeve with some low-surface-tension water (add detergent), feed the bellows with a slight twist in clockwise direction onto the shaft sleeve. **Use no oil or grease!** Apply pressure only on the corner rings.
- 7 Push a shaft sleeve (1900) on the pump shaft.
- 8 Bearing group 3 only: Fit a new gasket (1940).
- 9 Place the key (1890) in the pump shaft and push the pump wheel (1500) over the pump shaft.
- 10 Mount the gasket (1361).
- 11 Mount the pump cover (0110) in the right position into the fitting edge of the bearing bracket. Check whether the pump cover is at right angles to the pump shaft.
- 12 Mount the cover of the pump wheel casing (1510) against the pump cover. Watch its position in view of the connections. Tighten the Allen screws (1880) crosswise. **The cover should not be oblique.**
- 13 Push the other shaft sleeve (1900) on the pump shaft.
- 14 Bearing group 3 only: Fit a new gasket (1940).
- 15 Mount the impeller and other parts, see paragraph 7.7.2 "Assembly of the impeller".

7.8.4 Disassembly of the lip seals M4

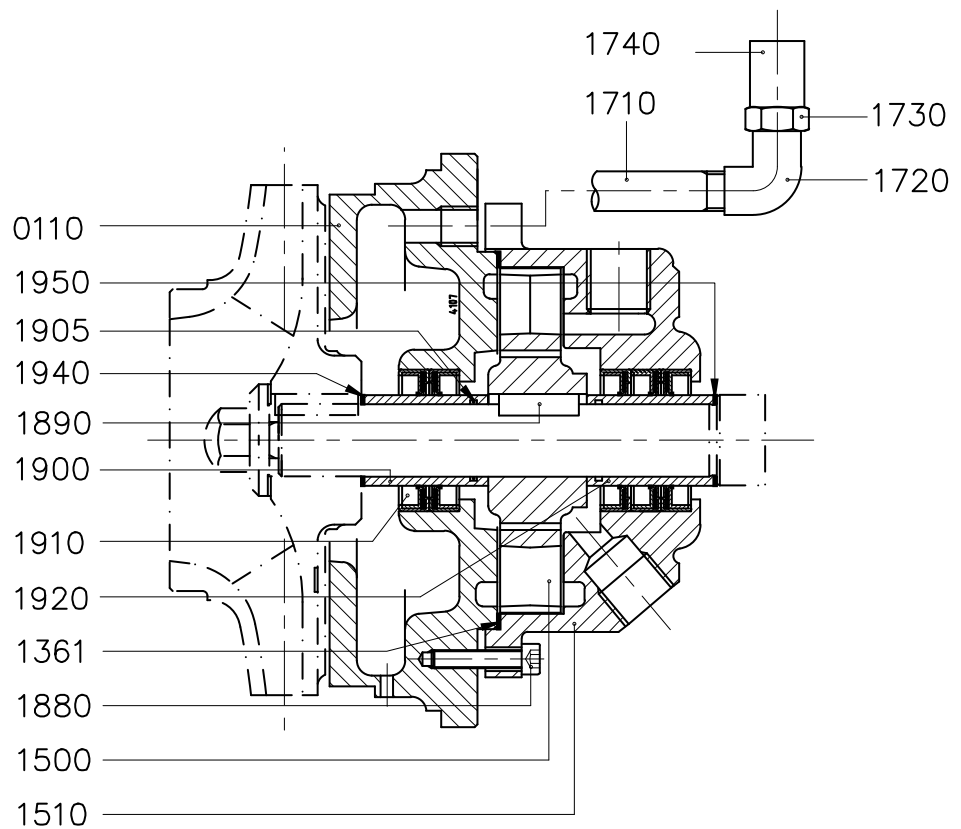

Figure 17: Lip seal M4.

The item numbers used are referring to figure 17.

- 1 Disassemble the impeller, see paragraph 7.7.1 "Disassembly of the impeller".
- 2 Mark the position of the pump cover (0110) in relation to the bearing bracket (2100).
- 3 Loosen the Allen screws (1880).
- 4 Push the cover of the pump wheel casing (1510) backward.
- 5 Knock the pump cover loose and push it off the pump shaft. Remove the tabbed sealing rings (1910).
- 6 Pull the shaft sleeve (1900) from the pump shaft and remove the O-ring (1905).
- 7 Pull the pump wheel (1500) from the pump shaft and remove the sunk key (1890).
- 8 Slide the cover of the pump wheel casing (1510) off the pump shaft and remove the tabbed sealing rings.
- 9 Remove the gasket (1361).
- 10 Pull the shaft sleeve (1920) from the pump shaft.
- 11 Remove the gasket (1950) from the pump shaft.

#### 7.8.5 Instructions for mounting a lip seal

➤ *First read the following instructions regarding the mounting of a lip seal. Follow these instructions closely when mounting a lip seal.*

- A lip seal is a fragile precision part, leave the seal in its original packing until you are ready to mount it.
- Clean all receiving parts properly.
- Make sure your hands and working environment are clean!

#### 7.8.6 Assembly of the lip seals M4

- 1 Check the shaft sleeves (1900 and 1920) and the splash ring (2220) for damages. Also, the splash ring should clasp the shaft properly. If necessary, replace these parts.
- 2 Place the bearing bracket with the shaft upright.
- 3 Mount the gasket (1950) around the pump shaft.
- 4 Slide the cover of the pump wheel casing (1510) onto the pump shaft.
- 5 Mount a lip seal on both ends of the shaft sleeve. The pointing direction of the tab should be opposite to the sliding direction. Shaft sleeve (1900) will have 2 lip seals, shaft sleeve (1920) will have 3. **When being mounted, the lip seals and the space between them both must be filled with grease.**
- 6 Slide the shaft sleeve (1920) onto the pump shaft.
- 7 Mount the sunk key (1890) in the pump shaft and slide the pump wheel casing (1500) onto the pump shaft.
- 8 Mount the pump cover (0110) in the right position in the fitting edge of the bearing bracket. Check the position of the pump cover. It should be at right angles to the pump shaft.
- 9 Mount the gasket (1361) between the pump cover and the pump wheel casing.
- 10 Mount the cover of the pump wheel casing (1510) against the pump cover. Watch the position in view of the place for the connections. Tighten the Allen screws (1880) crosswise. The cover should not be oblique.
- 11 Mount the O-ring (1905) into the shaft sleeve (1900) and slide the shaft sleeve onto the pump shaft.
- 12 Mount the impeller and the other parts, see paragraph 7.7.2 "Assembly of the impeller".

## 7.9 Bearing

### 7.9.1 Disassembly of bearings and pump shaft

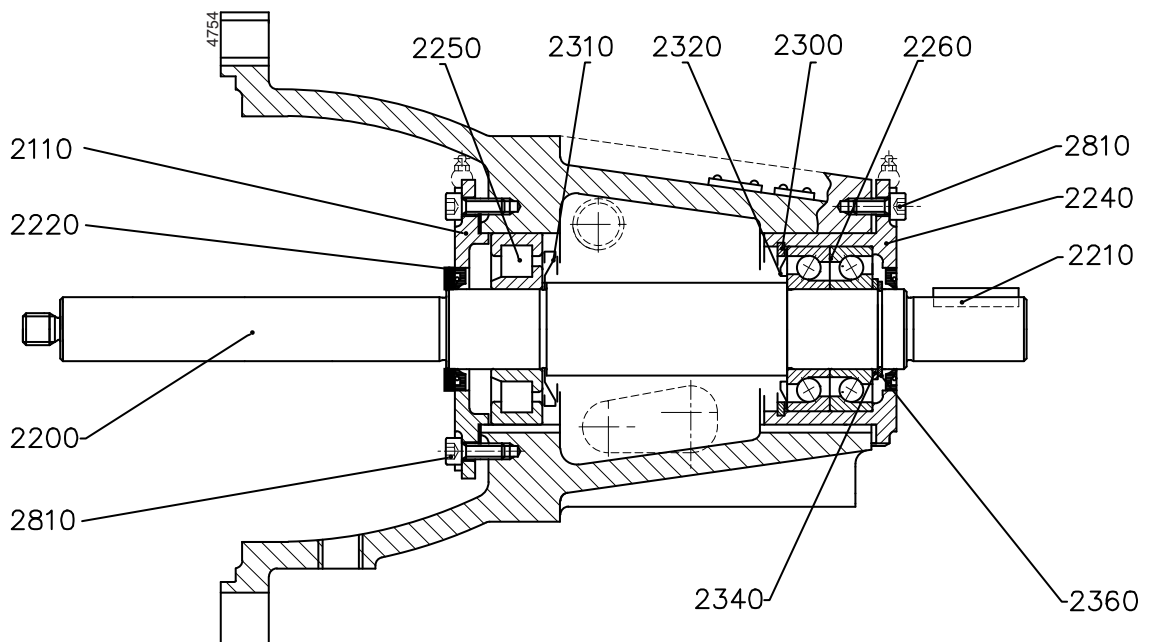

Figure 18: Bearing.

The item numbers used are referring to figure 18.

- 1 Disassemble the impeller and the shaft seal, see paragraph 7.7.1 "Disassembly of the impeller" and paragraph 7.8.1 "Disassembly of the mechanical seals M2" / paragraph 7.8.4 "Disassembly of the lip seals M4".
- 2 Remove the splash ring (2220).
- 3 Remove the Allen screws (2810) and the bearing cover (2110).
- 4 Knock the pump shaft (2200) on impeller side until the adjusting bush (2240) with the bearings (2260) comes out of the bearing bracket. Use a plastic hammer so as to avoid damage to the thread. Remove the pump shaft with the bearings from the bearing bracket.
- 5 Remove the coupling with a coupling puller and remove the coupling key (2210).
- 6 Loosen bolts (0235) and remove the assembly plate (0275).
- 7 Remove the inner circlip (2300) and pull the adjusting bush (2240) off the bearings.
- 8 Remove the outer circlip (2360) and the adjusting ring (2340) and pull the bearings from the pump shaft with a suitable puller. If such a puller is not available, knock the inner raceway of the bearing carefully. Use a normal hammer and a soft-metal drift.  
**Never knock with a hammer directly on the bearing!**
- 9 Remove the Nilos rings (2310 and 2320).

### 7.9.2 Assembly of bearings and pump shaft

**!** **Make sure your working environment is clean and leave the bearings in their original packing until you are ready to mount them.**

- 1 Clean the inside of the bearing bracket well.
- 2 Mount the Nilos rings (2310 and 2320) on the pump shaft. Make sure they are in the right place and position.
- 3 If possible, preheat the bearings to 90°C before mounting them on the pump shaft. The cylindrical bearing (2250) is to be mounted on the impeller side. The two angular contact bearings are mounted on the driving side **in O-arrangement**. Make sure all bearings are mounted straight on the pump shaft.

**!** **If preheating is not possible: never knock directly on the bearing! Use a mounting bush which is positioned against the inner raceway of the bearing and a normal hammer. A soft hammer may loose splinters which might damage the bearing.**

- 4 Mount the adjusting ring (2340) and mount the outer circlip (2360).
- 5 Grease the bearings. See paragraph 10.1 "Recommended greases" for recommended grease types.
- 6 Press the adjusting bush (2240) over the two angular contact bearings and place the inner circlip (2300) in the adjusting bush. Make sure the inner circlip falls into the groove.
- 7 Mount the shaft with the bearings into the bearing bracket from the motor side. Knock the shaft end on the coupling side until the first bearing (2250) slides through the bearing boring.
- 8 Carefully knock the shaft further into the bearing bracket until the adjusting bush (2240) is completely inside the bearing block. The shaft with the bearings should enter straight into the bearing bracket.
- 9 Mount the bearing cover (2110) and the splash ring (2220).
- 10 Mount the set screws (1930) and the Allen screws (2810) and adjust the axial play as described in 7.9.
- 11 Mount the self-priming part and the impeller as described in paragraph 7.8 "Shaft sealing" and paragraph 7.7.2 "Assembly of the impeller".

### 7.10 Adjustment of the axial play

After repairs to the pump, the axial play of the pump wheel has to be adjusted. This play should be the same on both sides. To adjust the play proceed as follows, see figure 19:

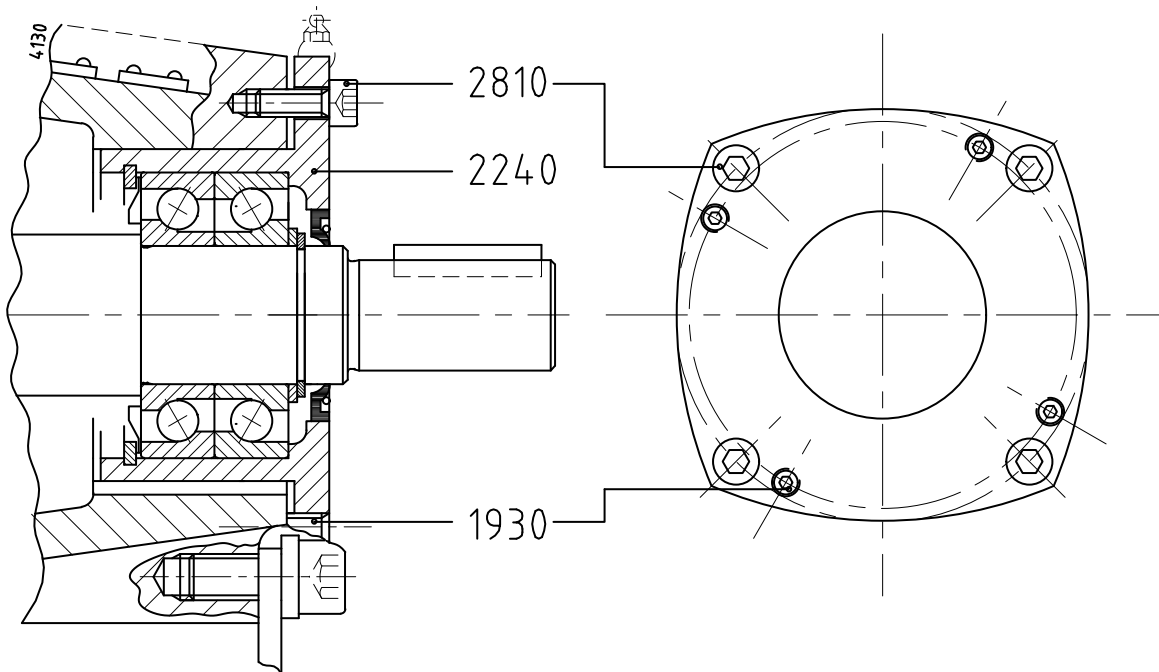

Figure 19: Adjustment of the axial play.

- 1 Loosen the set screws (1930).
- 2 Tighten the Allen screws (2810) crosswise. The adjusting bush (2240) with the bearing, pump shaft and pump wheel is shifting to the left. Turn the pump shaft by hand whilst tightening the screws. Tighten the Allen screws until you feel that the pump wheel starts to drag.
- 3 Screw the set screws (1930) so far into the adjusting bush (2240) until they are just touching the bearing bracket.
- 4 Then loosen the Allen screws (2810) again.
- 5 Re-tighten the set screws (1930) crosswise, whilst turning the pump shaft by hand. Count the number of turns you can give the set screws until the pump wheel starts to turn.
- 6 Then loosen the set screws again by half of the number of tightening turns.
- 7 Now tighten the Allen screws (2810) properly, crosswise.
- 8 Verify that all 4 set screws are fixed tightly.
- 9 Verify that the pump shaft can be turned easily.

➤ *If you wish you can use a clock gauge instead of counting the number of tightening turns of the screws. Determine the position of the shaft end in the two extreme positions of the shaft. Then adjust the shaft end right in the middle of the measured values.*



# 8 Dimensions

## 8.1 Dimensions delivery flange

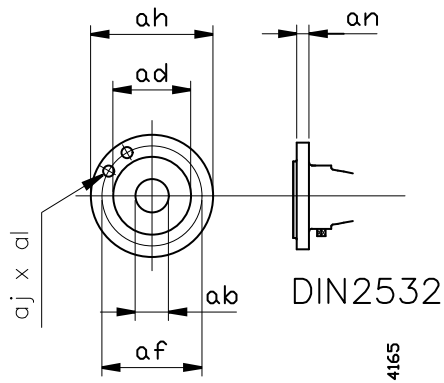

Figure 20: Dimensions delivery flange.

ab	ad	af	ah	aj * al	an
32	78	100	140	4*18	18
40	88	110	150	4*18	18
50	102	125	165	4*18	20
65	122	145	185	4*18	20
80	138	160	200	8*18	22
100	158	180	220	8*18	22
125	188	210	250	8*18	24
150	212	240	285	8*23	24
200	268	295	340	8*23	26
250	320	350	395	12*23	28

### 8.2 Dimensions suction flange

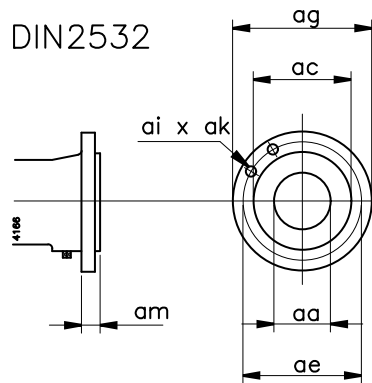

Figure 21: Dimensions suction flange.

aa	ac	ae	ag	ai * ak	am
65	122	145	185	4*18	20
80	138	160	200	8*18	22
100	158	180	220	8*18	22
125	188	210	250	8*18	24
150	212	240	285	8*22	24
200	268	295	340	8*22	26

### 8.3 Dimensions foot pads

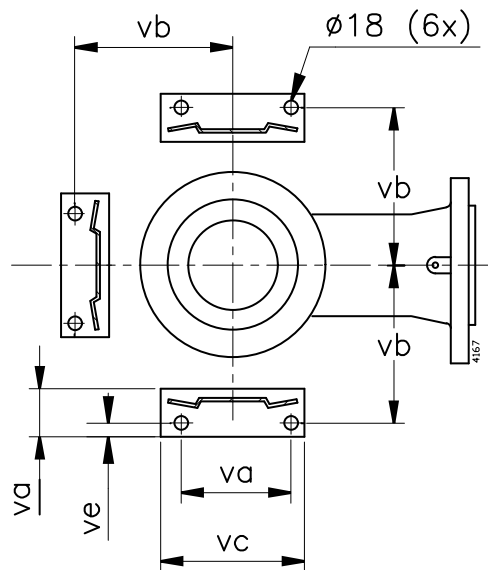

Figure 22: Dimensions foot pads (Top view).

CV	va	vb	vc	vd	ve
...-160	120	180	160	80	19
...-200	130	205	180	80	17
...-250	155	230	205	80	20
...-315	175	255	220	80	18
...-400	220	310	270	80	18

8.4 Dimensions pump

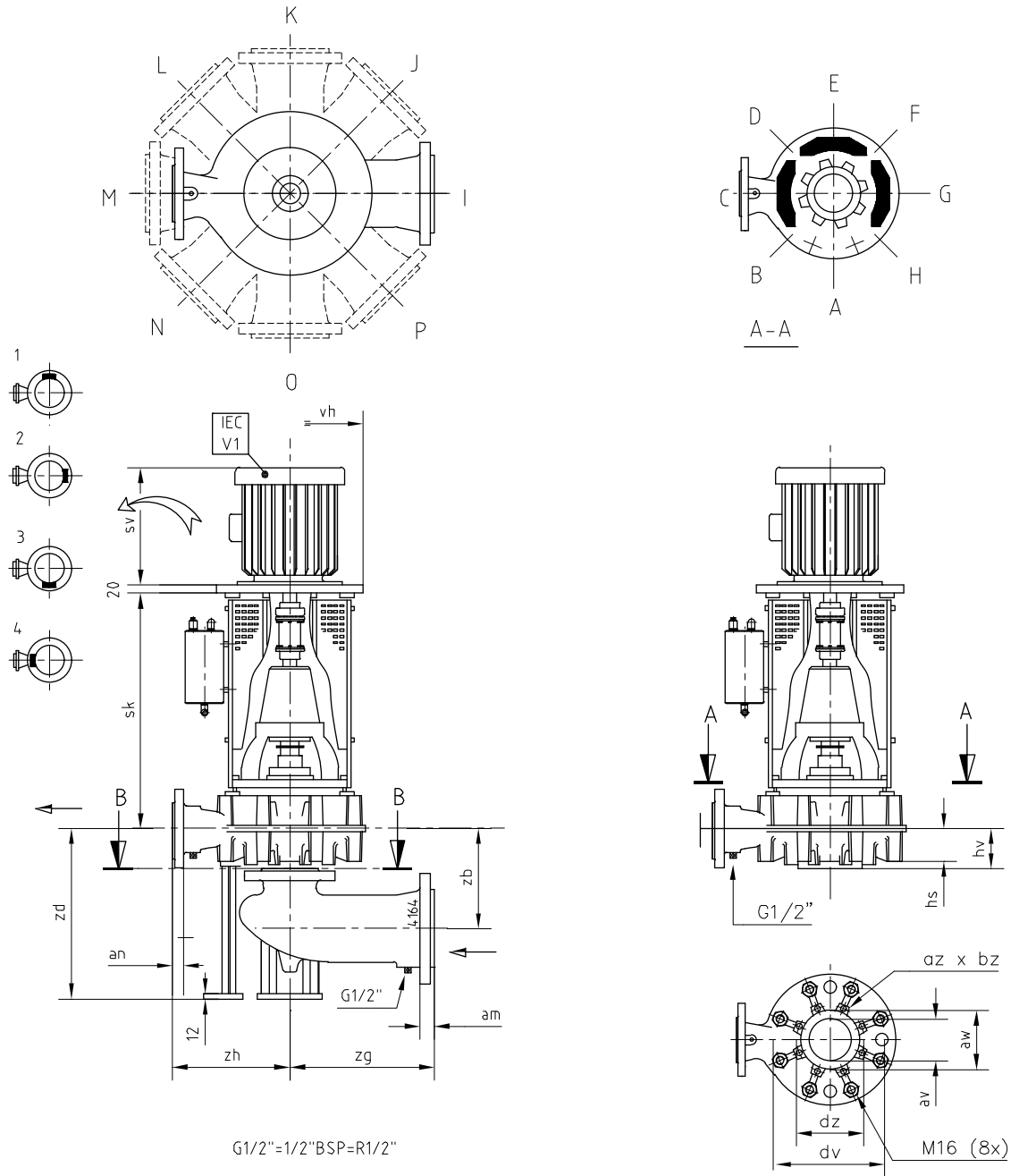

Figure 23: Pump dimensions.

Standard:

- disassembly opening lantern: pos A
- suction bend: pos I
- junction box electric motor: pos 1

CV	aa	ab	av	dv	hs	hv	zb	zd	zg	zh	sk			
											90S/L 100L 112M	132S/M	160M/L 180M/L 200L	225S/M 250M 280S/M
32-160	65	32	50	290	35	65	167	330	220	250	495	515		
32-200	80	32	65	340	35	65	177	350	220	280	495	520	550	
40-160	80	40	65	290	35	65	177	330	220	250	495	515		
40-200	80	40	65	340	35	80	192	350	220	280	495	520	550	
40-250	100	40	80	400	35	80	202	370	250	315	610	625	660	
50-160	80	50	65	290	50	80	192	345	220	250	500	525	545	
50-200	100	50	80	340	35	80	202	350	250	280	495	520	550	
50-250	100	50	80	400	35	80	202	370	250	315	610	625	660	
65-160	125	65	100	290	80	100	242	375	240	250		525	545	
65-200	125	65	100	340	60	80	222	375	240	280		525	550	
65-250	125	65	100	400	35	100	242	370	240	315	650	670	700	
65-315	125	65	100	450	75	100	242	455	240	315	710	720	750	
80-160	150	80	125	290	95	80	232	390	350	250		565	590	
80-200	150	80	125	340	85	100	252	400	350	280		670	700	730
80-250	150	80	125	400	65	100	252	400	350	315	650	670	700	730
80-315	150	80	125	450	55	100	252	455	350	315	710	720	750	
80-400	150	80	125	570	75	100	252	425	350	405		730	760	
100-200	150	100	125	340	100	100	252	415	350	280			700	730
100-250	150	100	125	400	85	100	252	420	350	315	650	665	700	730
100-315	150	100	125	450	75	100	252	475	350	315		720	750	
100-400	150	100	125	570	75	100	252	425	350	375		730	760	790
125-250	150	125	150	400	105	115	267	440	280	355		665	700	
125-315	150	125	150	450	95	125	277	495	280	355		730	760	790
125-400	150	125	150	570	75	125	277	425	280	400		730	760	790
150-315	200	150	200	450	120	140	342	520	350	400			760	790
150-400	200	150	200	570	120	140	342	470	350	450			760	790
200-200	150	200	150	400	150	185	387	485	280	400			695	
250B-315	200	250	200	450	150	135	387	550	350	500			760	790

(CV200-200 =.....-250)	vh															
	F165		F215		F265		F300				F350	F400		F500		
sv max	283	300	336	386	444	464	564	608	633	653	746	835	835	857	910	1023
CV	90S	90L	100	112M	132S	132M	160M	160L	180M	180L	200L	225S	225M	250M	280S	280M
...-160	350	350	350	350	350		350	350	350		400					
...-200			400	400	400		400	400	400		400		450	550	550	
...-250			450	450	450	450	450	450	450	450	450		450	550	550	550
...-315				550	550	550	550	550	550	550	550	550	550	550	550	550
...-400					620	620	620	620	620	620	620	620	620	620	620	620

av	aw	az*bz	dz
50	102	4*M16	125
60	122	4*M16	145
80	138	8*M16	160
100	158	8*M16	180
125	188	8*M16	210
150	212	8*M20	240
200	268	8*M20	295

8.5 Dimensions pump with service liquid tank

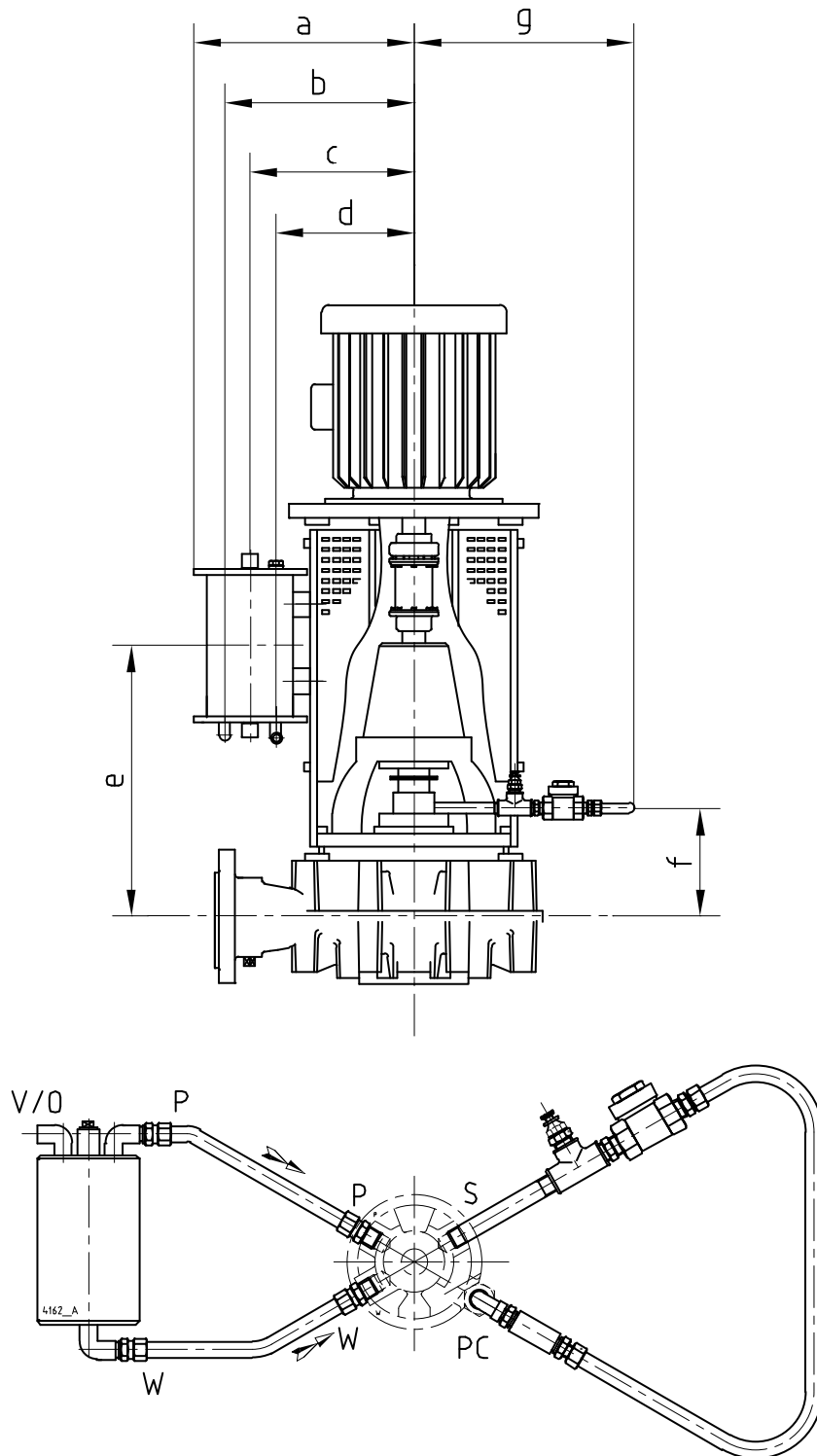

Figure 24: Pump with service liquid tank.

CV	a	b	c	d	e	f*	f**	g*	g**
32-160	263	237	204	188	285	115	--	330	--
32-200	286	260	227	211	285	114	--	330	--
40-160	263	237	204	188	301	116	--	330	--
40-200	286	260	227	211	285	116	--	330	--
40-250	314	288	255	239	285	131	146	330	440
50-160	263	237	204	188	315	118	--	330	--
50-200	286	260	227	211	315	116	--	330	--
50-250	314	288	255	239	285	133	148	330	440
65-160	263	237	204	188	315	126	--	330	--
65-200	286	260	227	211	315	120	--	330	--
65-250	314	288	255	239	310	133	148	330	440
65-315	446	328	328	328	325	--	155	--	440
80-160	263	237	204	188	335	125	--	330	--
80-200	286	260	227	211	340	131	--	330	--
80-250	314	288	255	239	310	136	151	330	440
80-315	337	311	278	262	325	--	155	--	440
80-400	392	366	333	317	335	--	154	--	440
100-200	286	260	227	211	340	128	--	330	--
100-250	314	288	255	239	340	137	152	330	440
100-315	337	311	278	262	325	--	157	--	440
100-400	392	366	333	317	335	--	154	--	440
125-250	314	288	255	239	285	--	158	--	440
125-315	337	311	278	262	335	--	162	--	440
125-400	392	366	333	317	335	--	158	--	440
150-315	337	311	278	262	335	--	166	--	440
150-400	392	366	333	317	335	--	158	--	440
200-200	314	288	255	239	310	--	169	--	440
250B-315	337	311	278	262	325	--	176	--	440

\* n = 3000-3600 min<sup>-1</sup>

\*\* n = 1500-1800 min<sup>-1</sup>

Connections

<b>V/O</b>	De-aeration / Overflow	Rp 1/2
<b>S</b>	Inlet self-priming pump	Rp 1/2
<b>SP</b>	Air-intake line	Rp 1/2
<b>P</b>	Outlet self-priming pump	Rp 1/2
<b>W</b>	Inlet service liquid	Rp 1/2

8.6 Dimensions pump with float de-aerator

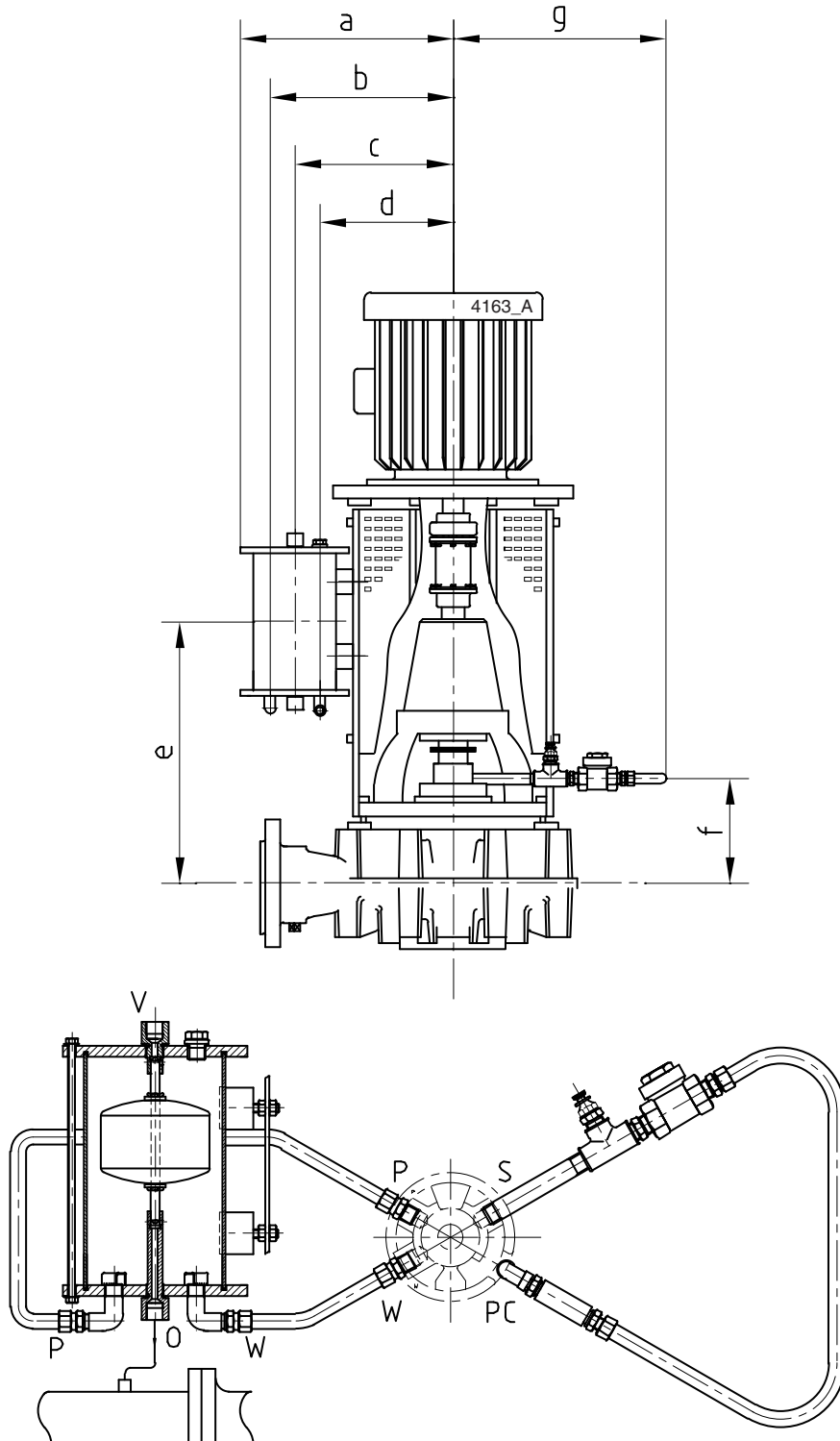

Figure 25: Pump with float de-aerator.

CV	a	b	c	d	e	f*	f**	g*	g**
32-160	372	254	254	254	285	115	--	330	--
32-200	395	277	277	277	285	114	--	330	--
40-160	372	254	254	254	301	116	--	330	--
40-200	395	277	277	277	285	116	--	330	--
40-250	423	305	305	305	285	131	146	330	440
50-160	372	254	254	254	315	118	--	330	--
50-200	395	277	277	277	315	116	--	330	--
50-250	423	305	305	305	285	133	148	330	440
65-160	372	254	254	254	315	126	--	330	--
65-200	395	277	277	277	315	120	--	330	--
65-250	423	305	305	305	310	133	148	330	440
65-315	446	328	328	328	325	--	155	--	440
80-160	372	254	254	254	335	125	--	330	--
80-200	395	277	277	277	340	131	--	330	--
80-250	423	305	305	305	310	136	151	330	440
80-315	446	328	328	328	325	--	155	--	440
80-400	501	383	383	383	335	--	154	--	440
100-200	395	277	277	277	340	128	--	330	--
100-250	423	305	305	305	340	137	152	330	440
100-315	446	328	328	328	325	--	157	--	440
100-400	501	383	383	383	383	--	154	--	440
125-250	423	305	305	305	285	--	158	--	440
125-315	446	328	328	328	335	--	162	--	440
125-400	501	383	383	383	335	--	158	--	440
150-315	446	328	328	328	335	--	166	--	440
150-400	501	383	383	383	335	--	156	--	440
200-200	423	383	383	383	310	--	169	--	440
250B-315	446	328	328	328	325	--	176	--	440

\* n = 3000-3600 min<sup>-1</sup>

\*\* n = 1500-1800 min<sup>-1</sup>

Connections

<b>V</b>	De-aeration	Rp 1/2
<b>O</b>	Drain waste water	Rp 1/2
<b>S</b>	Inlet self-priming pump	Rp 1/2
<b>SP</b>	Air-intake line	Rp 1/2
<b>P</b>	Outlet self-priming pump	Rp 1/2
<b>W</b>	Inlet service liquid	Rp 1/2

## 9 Parts

### 9.1 Ordering parts

#### 9.1.1 Order form

You can use the order form included in this manual for ordering parts.

When ordering parts always quote the following data:

- 1 Your **address**.
- 2 The **quantity, the item number and the description** of the part.
- 3 The **pump number**. The pump number is stated on the label on the cover of this manual and on the type plate of the pump.
- 4 In the event of different electric motor voltage you should state the correct voltage.

#### 9.1.2 Recommended spare parts

Parts marked with a \* are recommended spare parts.

**9.2 Pump parts**

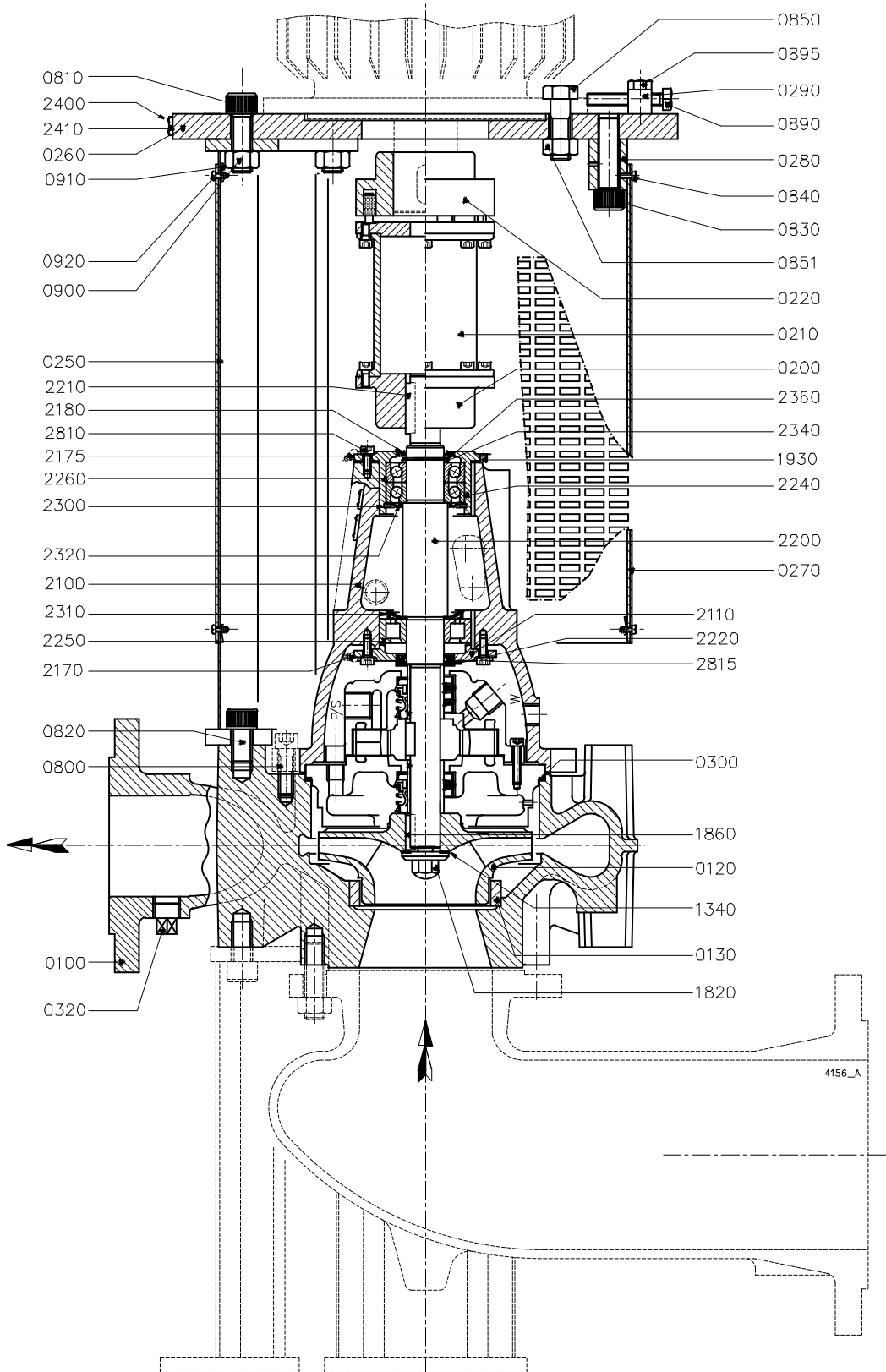

Figure 26: CombiPrime V.

Item	Quantity	Description	Material				
			G1	G2	G3	B2	B3
0100	1	pump casing	cast iron			bronze	
0120*	1	impeller	cast iron	bronze	aluminium bronze	bronze	aluminium bronze
0130*	1	wear ring	cast iron	bronze			
0200	1	coupling half pump side	cast iron				
0210	1	spacer sleeve	cast iron				
0220	1	coupling half motor side	cast iron				
0250	3	lantern	steel				
0260	1	flange	steel				
0270	5	guard	steel				
0280	2	assembling sleeve	steel				
0290	4	adjusting cam	steel				
0300*	1	gasket	--				
0320	1	plug	ductile cast iron			bronze	
0800	8/12 <sup>1)</sup>	Allen screw	steel			stainless steel	
0810	6	Allen screw	steel				
0820	6	Allen screw	steel				
0830	2	Allen screw	steel				
0840	2	screw	brass				
0850	4/8 <sup>2)</sup>	bolt	steel				
0851	4/8 <sup>2)</sup>	nut	steel				
0890	4	bolt	stainless steel				
0895	8	bolt	steel				
0900	6	nut	steel				
0910	14	speed nut	spring steel				
0920	14	tapped screw	stainless steel				
1340*	1	gasket	--				
1820*	1	cap nut	bronze				
1860*	1	impeller key	stainless steel				
1930	4	adjustment screw	stainless steel				
2100	1	bearing bracket	cast iron				
2110	1	bearing cover	cast iron				
2170	1	grease nipple	steel				
2175	1	grease nipple	steel				
2180	2	washer	rubber				
2200*	1	pump shaft	steel alloy			stainless steel	
2210*	1	coupling key	steel				
2220*	1	splash ring	rubber				
2240*	1	adjusting bush	cast iron				
2250*	1	roller bearing	--				
2260*	2	angular contact ball-bearing	--				
2300*	1	inner circlip	spring steel				

Item	Quantity	Description	Material				
			G1	G2	G3	B2	B3
2310*	1	nilos ring			steel		
2320	1	nilos ring			steel		
2340	1	adjusting ring			steel		
2350	1	spacer sleeve			steel		
2360*	1	outer circlip			spring steel		
2400	1	nameplate			stainless steel		
2410	1	arrow plate			aluminium		
2810	4	Allen screw			steel		
2815	4	Allen screw			steel		

1) Quantity dependent on pump type.

2) Quantity dependent on motor type.

9.3 Parts of shaft sealing group M2

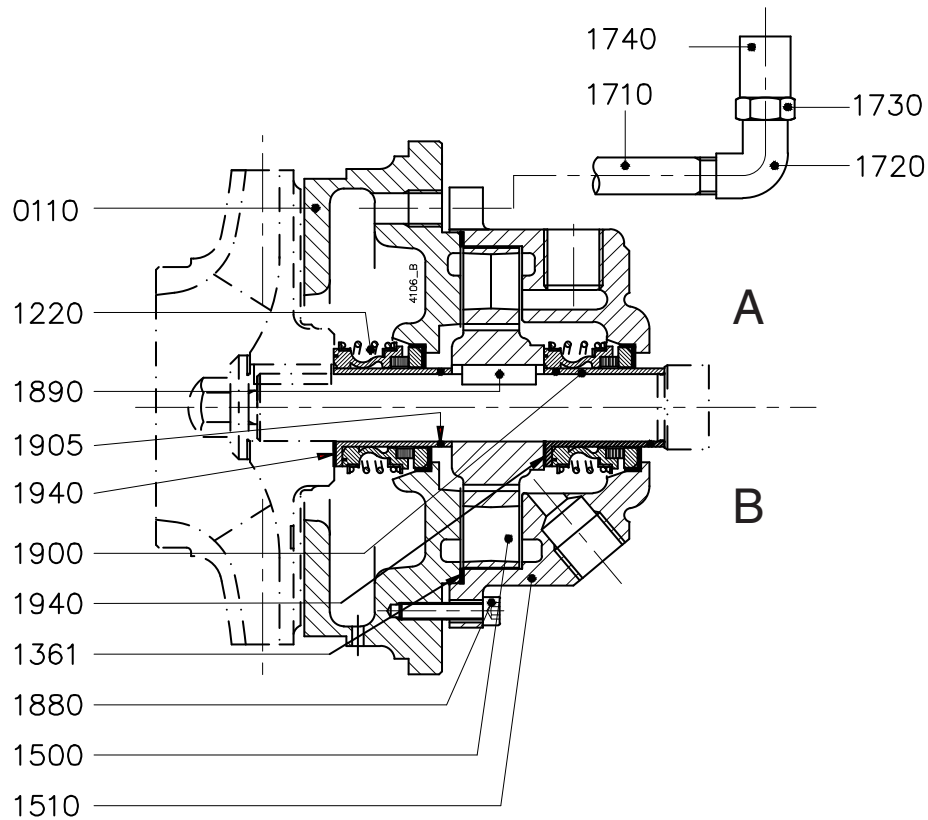

Figure 27: Parts of shaft sealing group M2  
(A = bearing group 1 and 2, B = bearing group 3).

Item	Quantity	Description	Material				
			G1	G2	G3	B2	B3
0110	1	pump cover	cast iron		bronze		
1220*	2	mechanical seal	--				
1361*	1	gasket	--				
1500*	1	air-wheel	bronze				
1510	1	self-priming casing	cast iron		bronze		
1710	1	pipe nipple <sup>1)</sup>	steel		stainless steel		
1720	1	knee <sup>1)</sup>	ductile cast iron		stainless steel		
1730	1	reducing nipple <sup>1)</sup>	ductile cast iron		stainless steel		
1740	1	socket <sup>1)</sup>	steel		stainless steel		
1880	8	Allen screw	steel		stainless steel		
1890	1	sunk key	stainless steel				
1900*	2	shaft sleeve	stainless steel				
1905*	2	O-ring	viton				
1940**	2	gasket	--				

<sup>1)</sup> Items 1710, 1720, 1730 and 1740 only for the pump types with a nominal impeller diameter of 160 and 250 mm ( $n = 1500 / 1800 \text{ min}^{-1}$ )

\*\* only for bearing bracket group 3

### 9.4 Parts of shaft sealing group M4

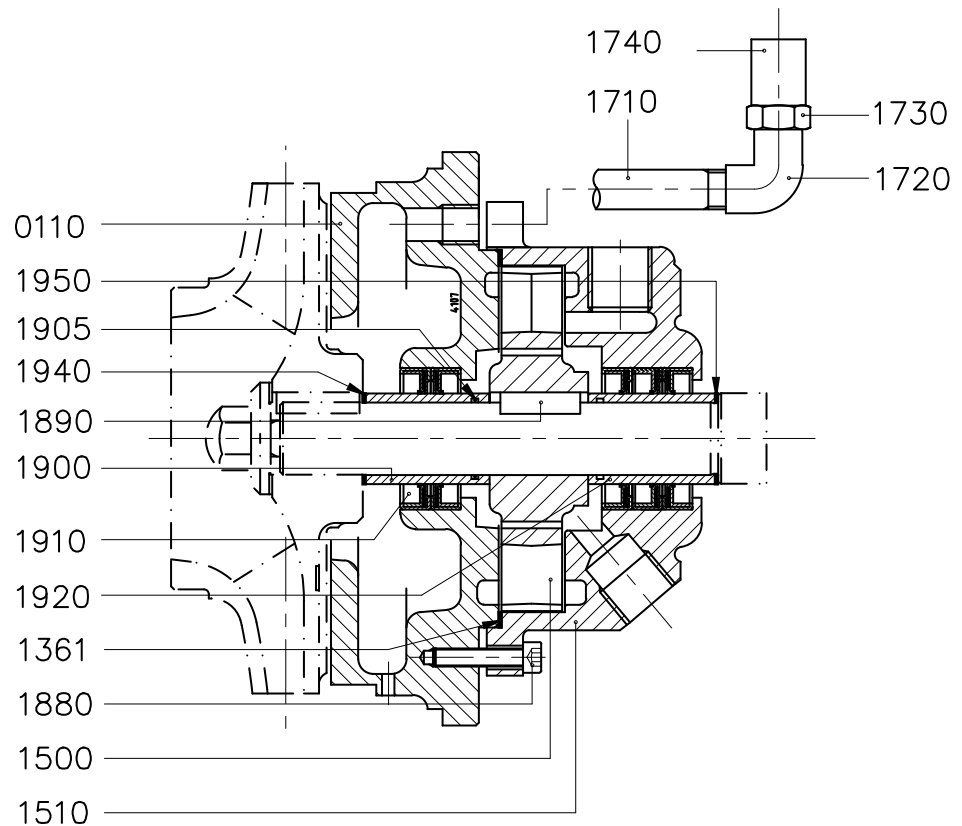

Figure 28: Parts of shaft sealing group M4.

Item	Quantity	Description	Material				
			G1	G2	G3	B2	B3
0110	1	pump cover	cast iron			bronze	
1361*	1	gasket	--				
1500*	1	air-wheel	bronze				
1510	1	self-priming casing	cast iron			bronze	
1710	1	pipe nipple <sup>1)</sup>	steel			stainless steel	
1720	1	knee <sup>1)</sup>	ductile cast iron			stainless steel	
1730	1	reducing nipple <sup>1)</sup>	ductile cast iron			stainless steel	
1740	1	socket <sup>1)</sup>	steel			stainless steel	
1880	5	Allen screw	steel			stainless steel	
1890	1	sunk key	stainless steel				
1900*	1	shaft sleeve	stainless steel with wearing layer				
1905*	1	O-ring	viton				
1910*	5	lip seal	PTFE				
1920*	1	shaft sleeve	stainless steel with wearing layer				
1940*	1	gasket	--				
1950*	1	gasket	--				

<sup>1)</sup> Items 1710, 1720, 1730 and 1740 only for the pump types with a nominal impeller diameter of 160 and 250 mm ( $n = 1500 / 1800 \text{ min}^{-1}$ )

9.5 Parts of service liquid tank TL

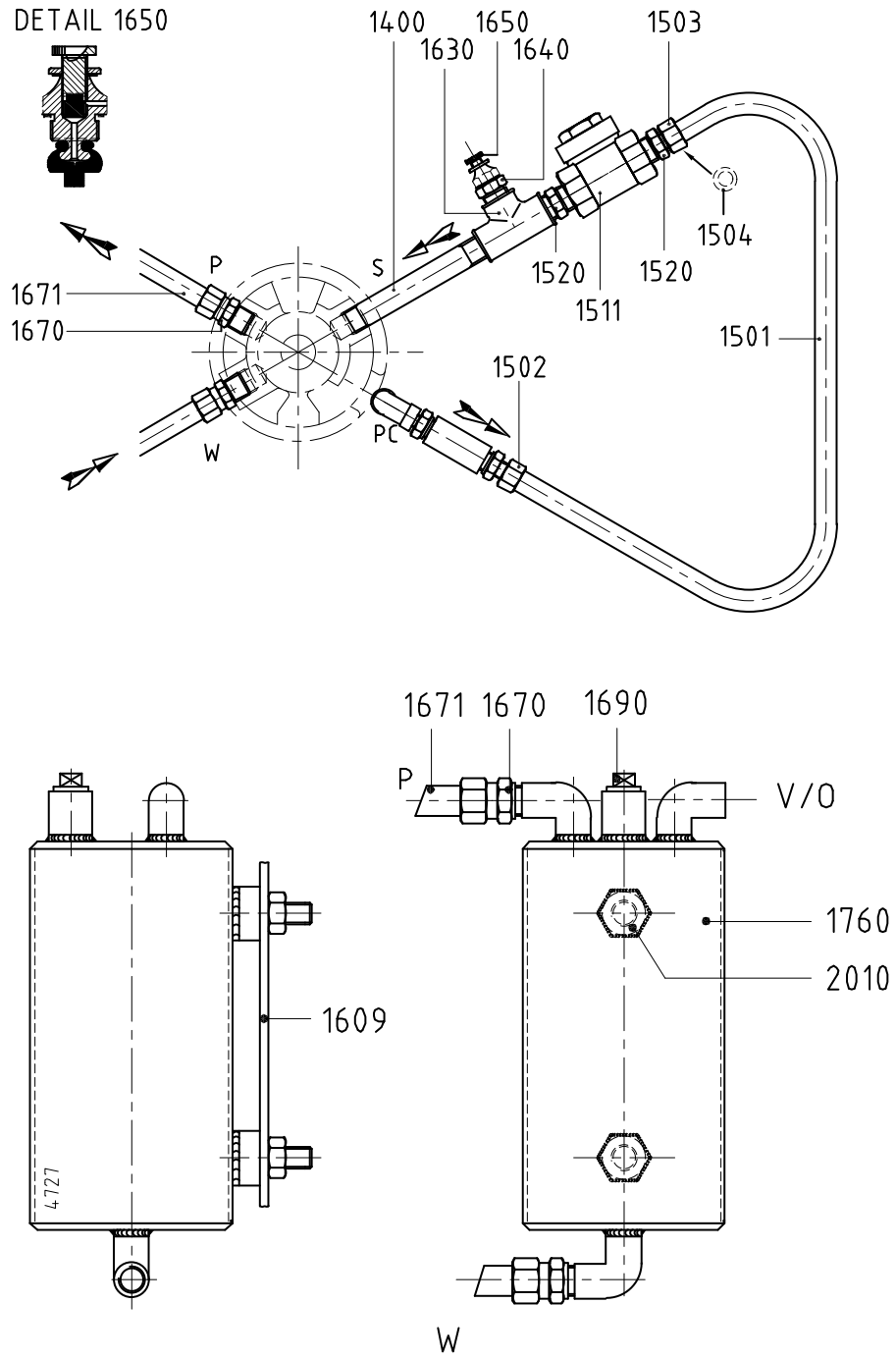

Figure 29: Parts of service liquid tank TL.

Item	Quantity	Description	Material				
			G1	G2	G3	B2	B3
1400	1	pipe nipple	stainless steel				
1501	1	pipe	stainless steel				
1502	1	male connector	stainless steel				
1503	2	male connector	steel		stainless steel		
1504*	1	washer	stainless steel				
1511	1	non return valve	NBR/brass		stainless steel		
1550	1	elbow connector	steel		stainless steel		
1609	1	tank support	steel				
1630	2	T-piece	ductile iron		stainless steel		
1640	1	reducing ring	ductile iron		stainless steel		
1650	1	air inlet valve	brass				
1670	4	male connector	steel		stainless steel		
1671	1	pipe	stainless steel				
1690	1	plug	ductile iron		bronze		
1760	1	tank	stainless steel				
2010	2	nut	steel		stainless steel		

\* If the delivery head is over 30 m throttling is applied in order to create a vacuum behind the air inlet valve.

9.6 Parts of float de-aerator VL

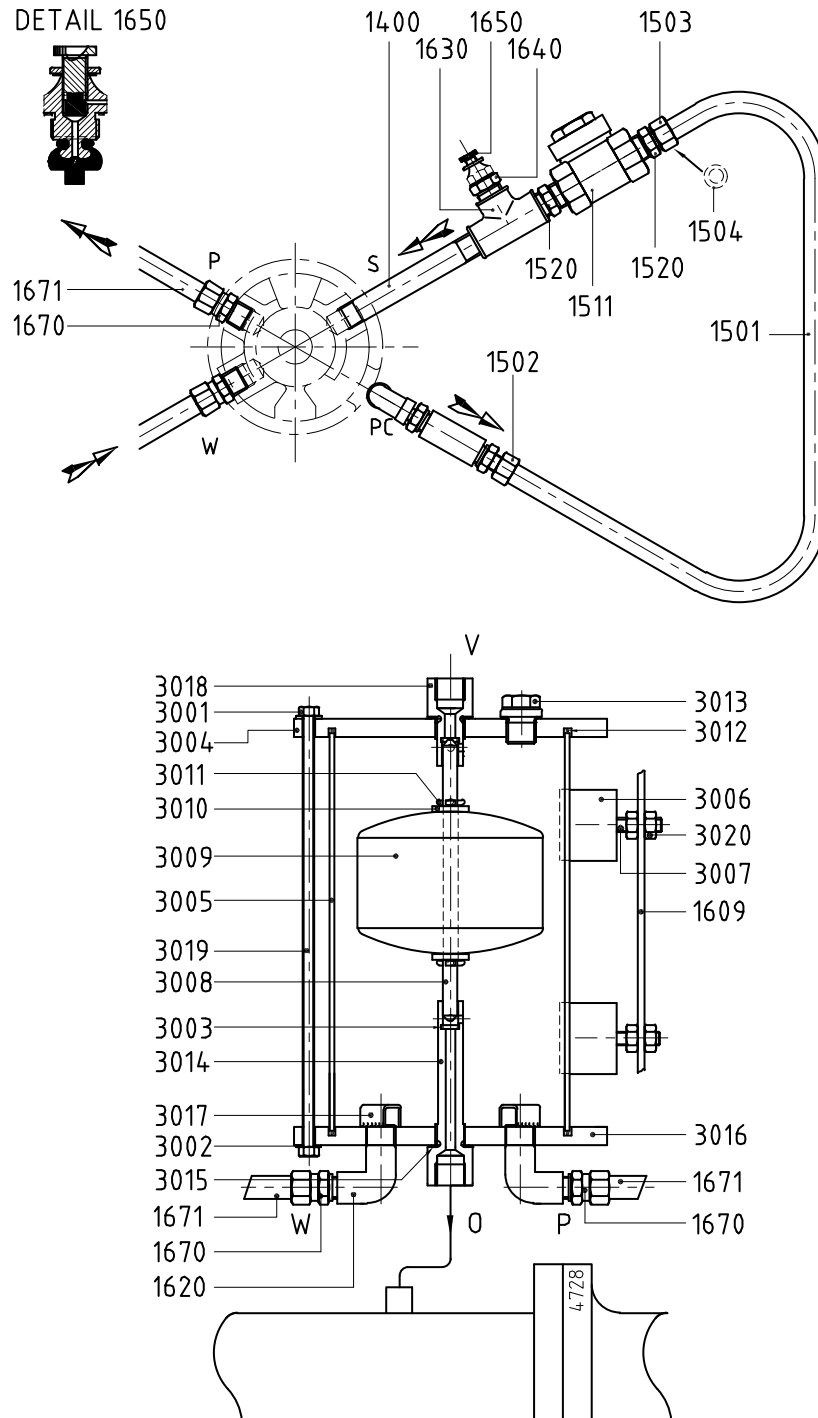

Figure 30: Parts of float de-aerator VL.

Item	Quantity	Description	Material				
			G1	G2	G3	B2	B3
1400	1	pipe nipple	stainless steel				
1501	1	pipe	stainless steel				
1502	1	male connector	stainless steel				
1503	2	male connector	steel		stainless steel		
1504**	1	washer	stainless steel				
1511	1	non-return valve	NBR/brass		stainless steel		
1520	2	double nipple	ductile iron		stainless steel		
1609	1	tank support	steel				
1630	1	T-piece	ductile iron		stainless steel		
1640	1	reducing ring	ductile iron		stainless steel		
1650	1	air-inlet valve	brass				
1670	4	male connector	steel		stainless steel		
1671	1	pipe	stainless steel				
2010	2	nut	steel		stainless steel		
3001	8	nut	stainless steel				
3002	8	washer	stainless steel				
3003*	2	O-ring	NBR				
3004	1	cover	stainless steel				
3005	1	jacket	stainless steel				
3006	2	bow	stainless steel				
3007	2	tap bolt	stainless steel				
3008*	1	float needle	POM				
3009*	1	float	stainless steel				
3010*	2	washer	stainless steel				
3011*	2	split pin	stainless steel				
3012*	2	O-ring	Viton				
3013	1	plug	stainless steel				
3014	1	long valve seat	stainless steel				
3015	3	joint ring	gylon				
3016	1	bottom	stainless steel				
3017	2	bow	stainless steel				
3018	1	short valve seat	stainless steel				
3019	4	draw bar	stainless steel				
3020	4	nut	stainless steel				

\*\* If the delivery head is over 30 m throttling is applied in order to create a vacuum behind the air inlet valve.

9.7 Parts of suction bend

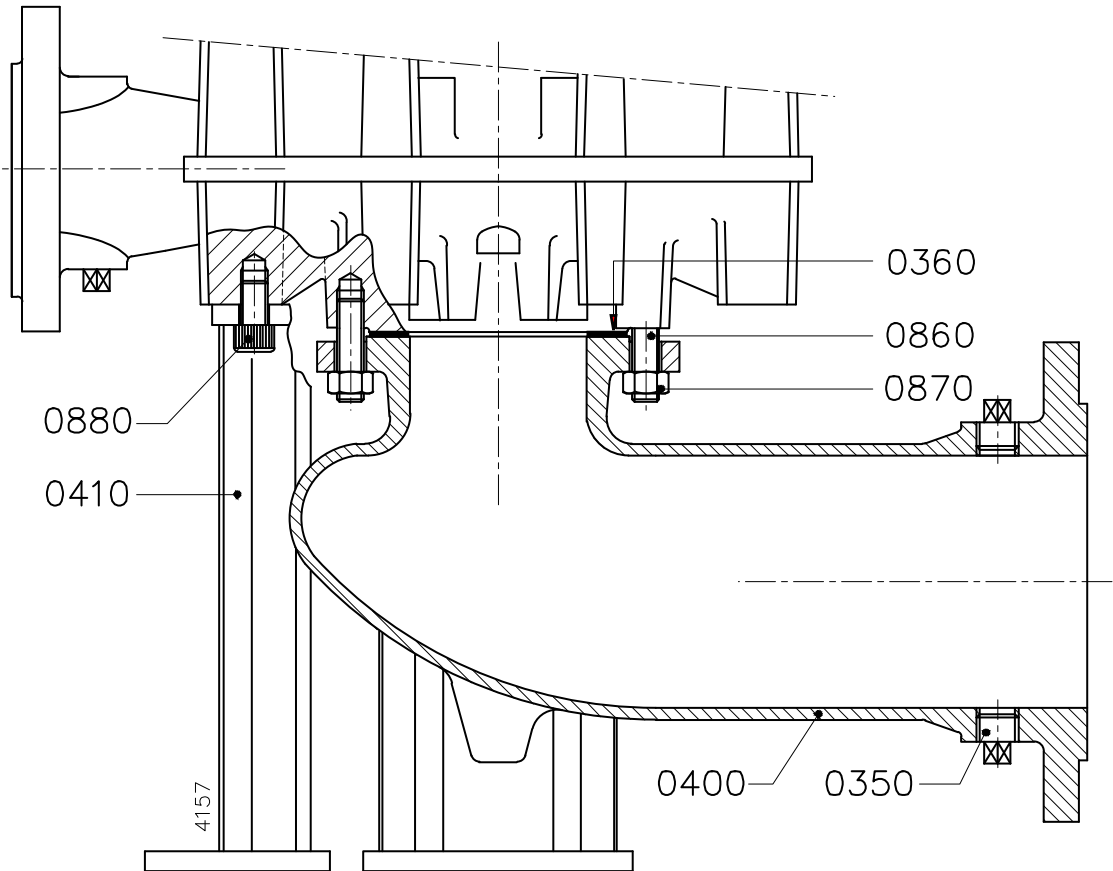

Figure 31: Suction bend.

Item	Quantity	Description	Material	
			cast iron	bronze
0350	2	plug	steel	stainless steel
0360	1	gasket	rubber	
0400	1	suction bend	cast iron	bronze
0410	3	supporting foot	steel	
0860	4/8 <sup>1)</sup>	stud	steel	
0870	4/8 <sup>1)</sup>	nut	steel	
0880	6	Allen screw	steel	

<sup>1)</sup> Quantity dependent on pump type.



# 10 Technical data

## 10.1 Recommended greases

Recommended greases according to classification NLGI-2.

BP	Energrease LS 2
SHELL	Alvania R2
MOBIL	Mobilux EP 2
TOTAL	Multis EP-22
CHEVRON	Polyurea EP Grease-2
ESSO	Beacon 2
FINA	Marson L2
TEXACO	MultifaK EP-2
SKF	Alfalub LGMT 3
Hoeveelheid/Lager [gr] = 0,005 * Buitendiameter [mm] * Lagerbreedte [mm]	

## 10.2 Recommended locking liquids

Description	Locking liquid
cap nut (1820)	Loctite 243
wear ring (0130)	Loctite 641

## 10.3 Tightening moments

### 10.3.1 Tightening moments for bolts and nuts

Materials	8.8	A2, A4
Thread	Tightening moment [Nm]	
M6	9	6
M8	20	14
M10	40	25
M12	69	43
M16	168	105

### 10.3.2 Tightening moments for cap nuts

Size	Tightening moment [Nm]
M12 (bearing group 1)	43
M16 (bearing group 2)	105
M24 (bearing group 3)	220

### 10.4 Hydraulic performance

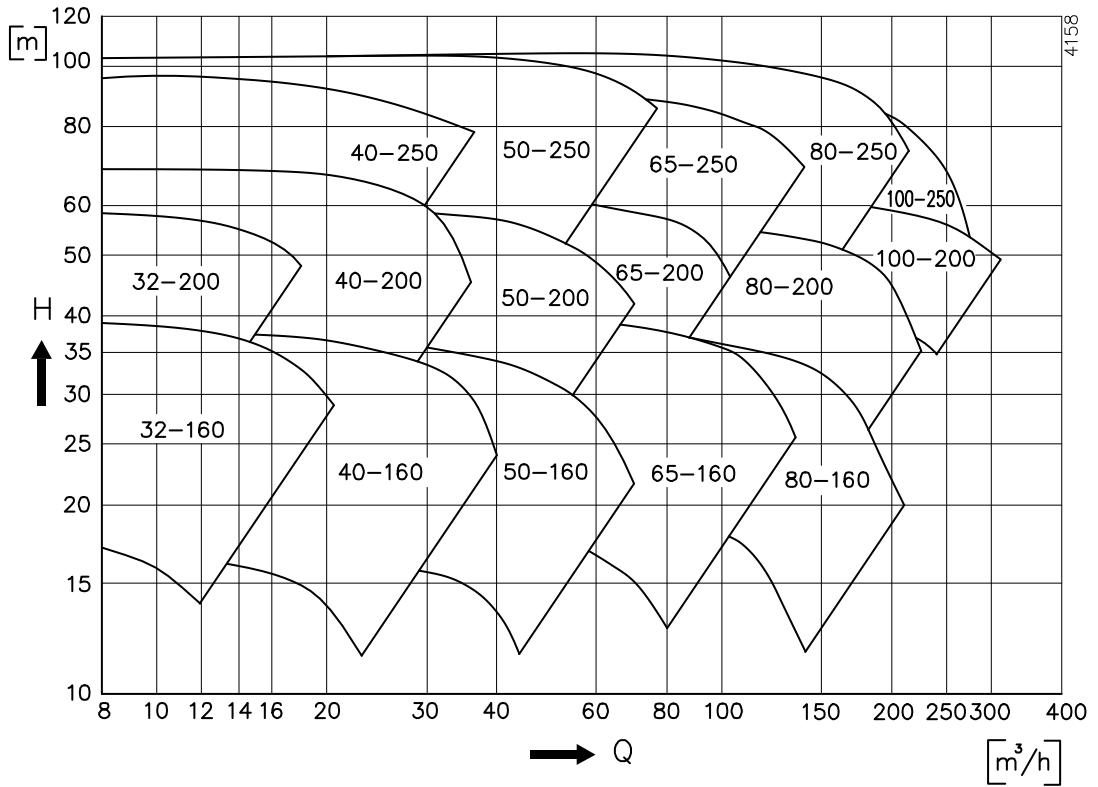

Figure 32: Performance overview 3000 min<sup>-1</sup>.

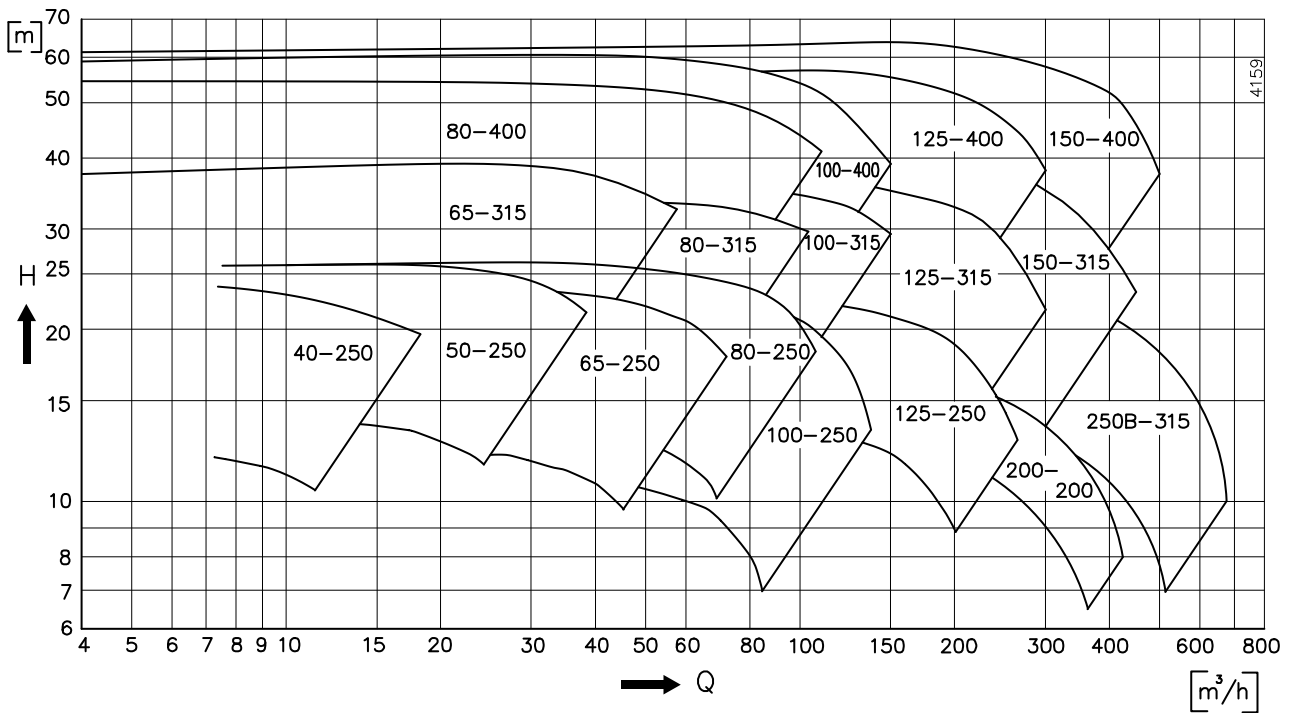

Figure 33: Performance overview 1500 min<sup>-1</sup>.

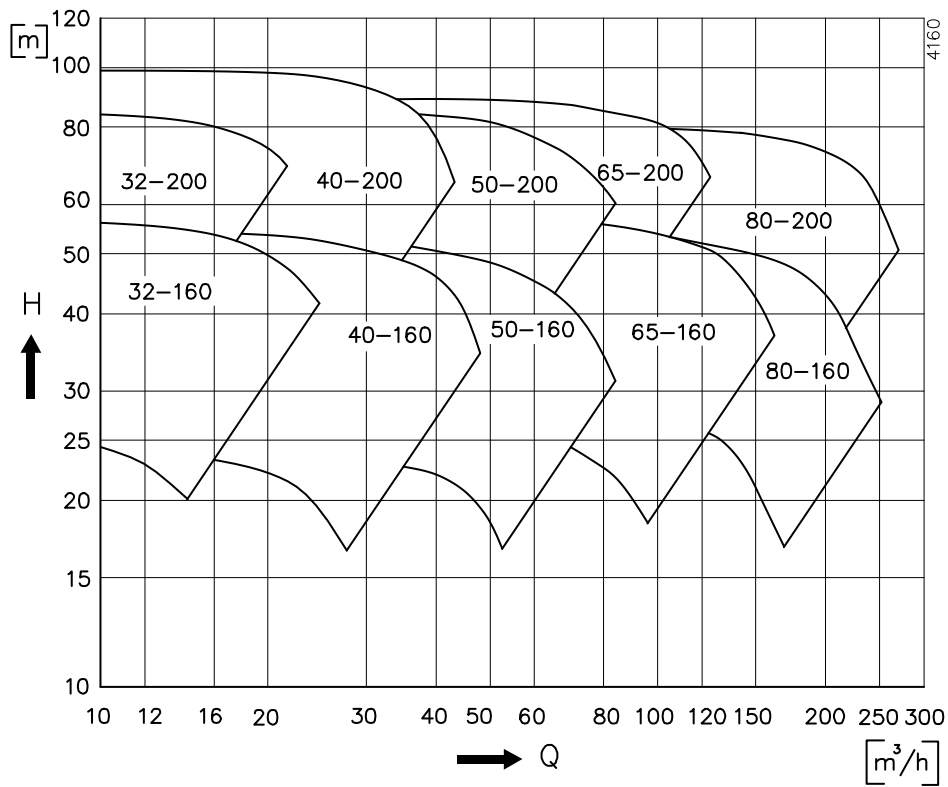

Figure 34: Performance overview 3600 min<sup>-1</sup>.

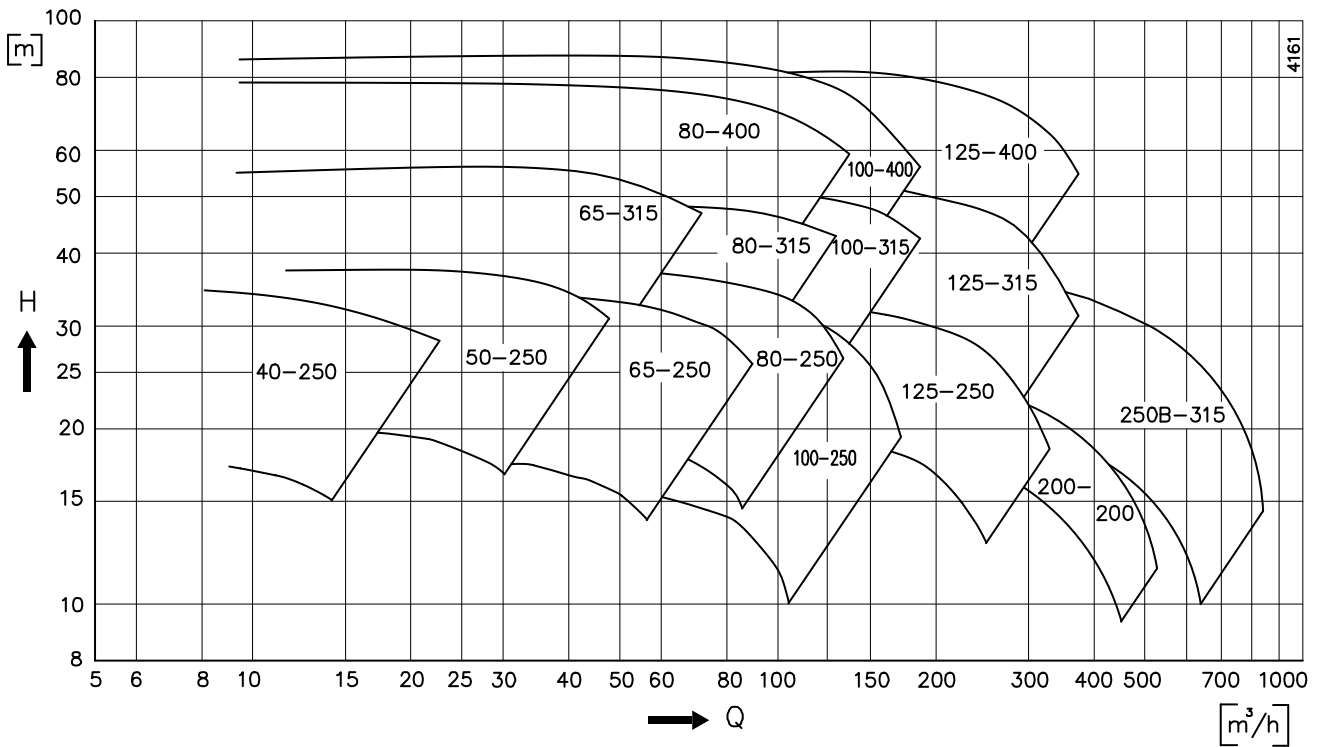

Figure 35: Performance overview 1800 min<sup>-1</sup>.

## 10.5 Noise data

### 10.5.1 Pump noise as a function of pump power

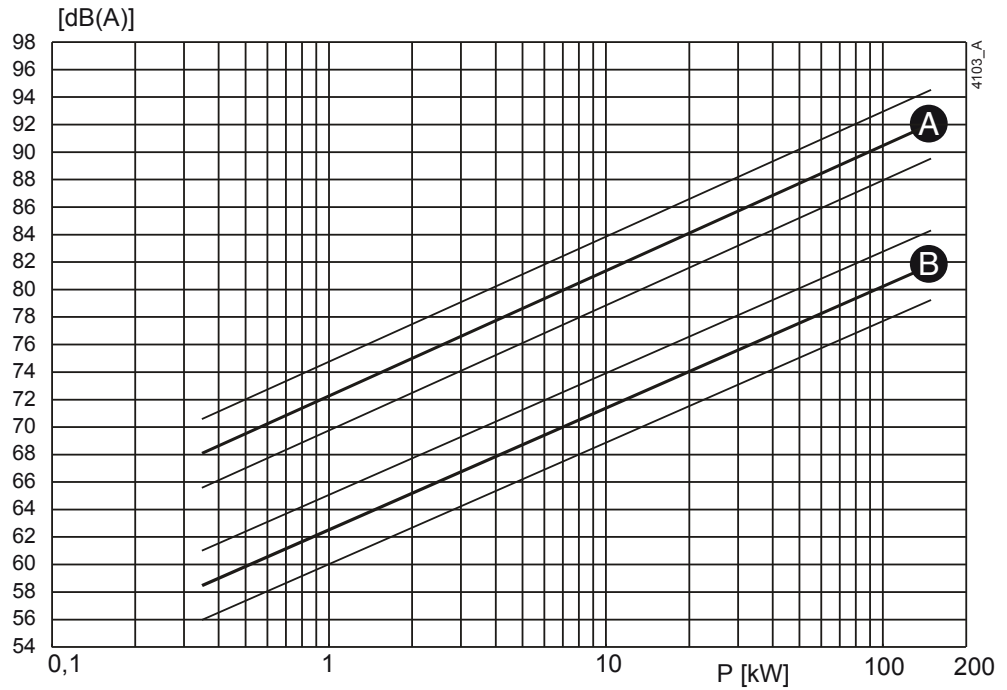

Figure 36: Noise level as function of pump power [kW] at  $1450 \text{ min}^{-1}$   
 A = sound energy, B = sound pressure.

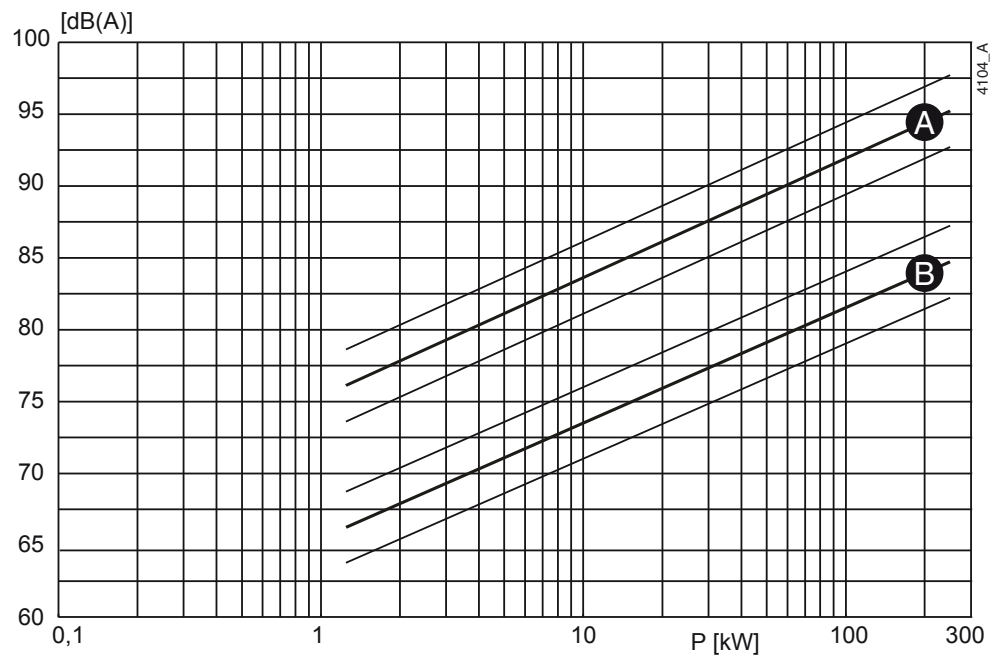

Figure 37: Noise level as function of pump power [kW] at  $2900 \text{ min}^{-1}$   
 A = sound energy, B = sound pressure.

10.5.2 Noise level of entire pump unit

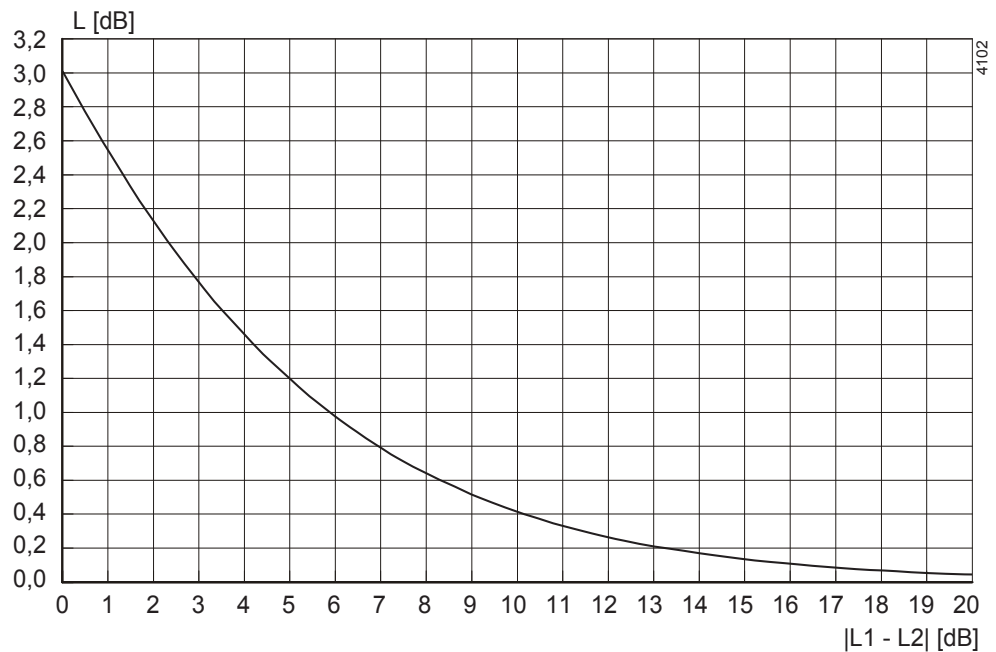

Figure 38: Noise level of entire pump unit.

In order to determine the total noise level of the entire pump unit, the noise level of the motor must be added to that of the pump. This can be easily done by using the graph above.

- 1 Determine the noise level (L1) of the pump, see figure 36 or figure 37.
- 2 Determine the noise level (L2) of the motor, see documentation of the motor.
- 3 Determine the difference between both levels |L1 - L2|.
- 4 Find the differential value on the |L1 - L2|-axis and go up to the curve.
- 5 From the curve go left to the L[dB] -axis and read out the value.
- 6 Add this value to the highest value of both noise levels (L1 or L2).

Example:

1. Pump 75 dB; motor 78 dB.
2.  $|75-78| = 3$  dB.
3. 3 dB on the X-axis = 1,75 dB on the Y-axis.
4. Highest noise level + 1,75 dB = 78 + 1,75 = 79,75 dB.



# Index

## A

Accessories  
 mounting ..... 20, 21, 26  
 Adjusting the air-inlet valve ..... 32  
 Adjustment of the axial play ..... 47  
 Application ..... 14  
 Application area ..... 15

## B

Bearing ..... 45  
 Bearings  
 assembly ..... 46

## C

Construction ..... 14, 15  
 bearing construction ..... 15  
 Foot pads ..... 15  
 impeller ..... 14  
 pump casing ..... 14  
 self-priming part ..... 15  
 shaft sealing ..... 14  
 Construction variants ..... 38  
 Coupling  
 alignment ..... 19

## D

Daily maintenance ..... 33

## E

Earthing ..... 17  
 Electric motor  
 connection ..... 30  
 Environment ..... 17  
 Environmental influences ..... 34

## F

Faults ..... 34  
 Foundation ..... 17

## G

Grease ..... 69

Guarantee ..... 10

## H

Hoisting ..... 11

## I

Impeller  
 assembly ..... 39  
 disassembly ..... 39  
 replacement ..... 39  
 Inspection  
 centrifugal pump part ..... 31  
 electric motor ..... 31  
 vacuum pump part ..... 31

## L

lantern ..... 15  
 Lifting eye ..... 11  
 Lip seal  
 assembly instructions ..... 44  
 Lip seals  
 assembly ..... 44  
 disassembly ..... 43  
 Liquid draining ..... 37  
 Lubrication of the bearings ..... 33

## M

Maintenance  
 lip seal ..... 33  
 mechanical seal ..... 33  
 Maintenance staff ..... 9  
 Mechanical seal ..... 32  
 assembly instructions ..... 42  
 Mechanical seals  
 assembly ..... 42  
 disassembly ..... 41  
 Monitoring ..... 32  
 Mounting ..... 18

**N**

Noise ..... 32, 34

**O**

Operational range .....70

**P**

Pallets .....11

Piping .....20

Precautionary measures .....37

Pump description .....13

Pump shaft  
assembly .....46

Pump unit  
assembly .....18

installation .....18

**R**

Recommended greases .....69

Recommended locking liquid .....69

Re-use .....16

**S**

Safety .....9  
symbols .....9

Scrapping .....16

Sense of rotation .....31

Service liquid .....33

Shaft sealing .....41

Start-up .....31

Static electricity .....17

Storage .....11

**T**

Technicians .....9

Tightening moments  
for bolts and nuts .....69

for cap nut .....69

Tools .....37

Top Pull Out system .....38

Top Pull Out unit  
assembly .....38

disassembly .....38

Transport .....11

Type code .....13

**V**

Vacuum pump with float-controlled de-aerator  
.....26

Vacuum pump with service liquid tank ...21

Ventilation .....17

**W**

Wear ring  
assembly .....40

disassembly .....40

replacement .....39

Working switch .....30





**SPX**<sup>®</sup>

**PROCESS EQUIPMENT**

Your local contact:



SPX Process Equipment NL B.V.  
Dr. A. F. Philipsweg 51 - P.O. Box 9 - 9400 AA ASSEN - THE NETHERLANDS  
Phone: + 31 (0) 592 37 67 67 Fax: + 31 (0) 592 37 67 60  
E-Mail: [jp-industry.nl@processequipment.spx.com](mailto:jp-industry.nl@processequipment.spx.com)

For more information about our worldwide locations, approvals, certifications, and local representatives, please visit [www.johnson-pump.com](http://www.johnson-pump.com) and [www.spxpe.com](http://www.spxpe.com).

SPX Corporation reserves the right to incorporate our latest design and material changes without notice or obligation. Design features, materials of construction and dimensional data, as described in this bulletin, are provided for your information only and should not be relied upon unless confirmed in writing. Certified drawings are available upon request.

© 2008 SPX Corporation