



**I Applications**

The SLR pump is lobular rotating pump with positive displacement and a sanitary design suitable for use in the dairies, food-processing, beverage, pharmaceutical and fine chemicals industries.

This pump is perfect for managing all kinds of fluid, of either low or high viscosity, in the food-processing, dairies, and cosmetics industries, as well as for filtering and bottling applications. Fluids containing fragile solids such as junket can be pumped without damage thanks to the specially designed lobes.

**I Operating principles**

The SLR pumps basically consist of two lobe rotors which rotate synchronously inside a casing without touching each other.

As the rotors rotate, the spaces between the lobes and the casing are successively filled with fluid, which is transported to the discharge nozzle with a fixed amount of displacement. The pumped fluid forms a continuous stream thanks to the tolerances between the lobes and the pump casing, thus ensuring an efficient pumping.

**I Design and features**

- Bare-shaft construction.
- Casing and rotors in stainless steel investment casting technology.
- Tri-lobe rotors.
- Health-safe design of the attachment of the rotors.
- DIN connections (standard)
- Sanitary mechanical seals.
- Easy cleaning and maintenance.
- Pump certified according to 3A sanitary standards.

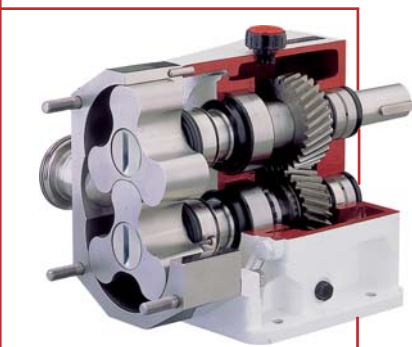

**I Materials**

Parts in contact with pumped media:	AISI 316L
Support:	GG-15
Gaskets (standard)	EPDM (FDA)
Mechanical seals (standard)	C/SiC/EPDM
Inside Surface Finishing	Ra ≤ 0.8 µm.
Outside Surface Finishing	Mirror polished



**I Options**

- Mech.seals in SiC/SiC, TgC/SiC, C/St.St
- Ra ≤ 0.4 μm surface finishing
- Cooled-seal packing, pressurized double seal, lip seal, or O-ring seal.
- Gaskets in FPM (Viton®) and PTFE
- Relief valve on the front cover or external by-pass.
- Bi-wing lobes.
- Heating chambers.
- Isolation can.
- Vertical support.
- Rectangular nozzle
- Several kinds of drives and protections (gearbox drive with optional frequency converter, pulley/mechanical drive speed selector)
- Trolley and/or Switchboard.
- Connections: Clamp, SMS, RJT...



**I Technical specifications**

Max.flow	160m <sup>3</sup> /h / 705 GPM
Max.head	22 bar / 320 PSI.
Max.working temp.	120 °C / 248 ° F
Max.speed	1450 min-1

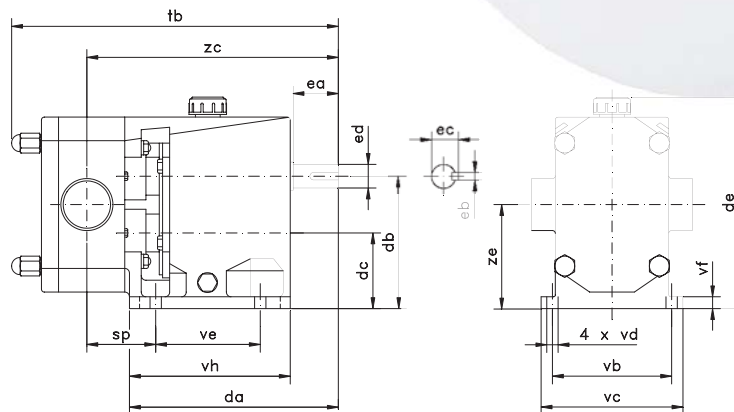

SLR	DN	da	db	dc	de	ea	eb	ec	ed	sp	tb	vb	vc	vd	ve	vf	vh	zc	ze
0-10	10-1/2"	160	80	40	138	30	5	16,2	14	61	253	102	118	9	50	9	65	213	60
0-20	20-3/4"									64	261							216	
0-25	25-1"									68	269							220	
1-20	20-3/4"	187	112	62	186	40	6	21,6	19	67	280	115	135	9	85	10	145	221	87
1-25	25-1"									64	280							218	
1-40	40-1 1/2"									70	292							224	
2-25	25-1"	221	140	78	224	50	8	27	24	80	337	125	150	11	105	12	169	267	109
2-40	40-1 1/2"									74	337							261	
2-50	50-2"									80	349							267	
3-40	40-1 1/2"	297	190	97	289	80	10	41,4	38	97	430	170	210	13	130	14	214	354	143,5
3-50	50-2"									91	430							348	
3-80	80-3"									101	452							360	
4-50	50-2"	433	240	120	366	110	16	58,9	55	117	627	260	290	18	280	15	320	530	180
4-100	100-4"									92	627							505	
4-150	150-6"									117	677							530	
5-125	125-5"	567	350	178	508	140	18	64,3	60	118	793	380	420	18	373	29	423	660	264
5-150	150-6"									130	818							672	

